

# LEVEL VIEW™

## PUMP STATION CONTROLLER

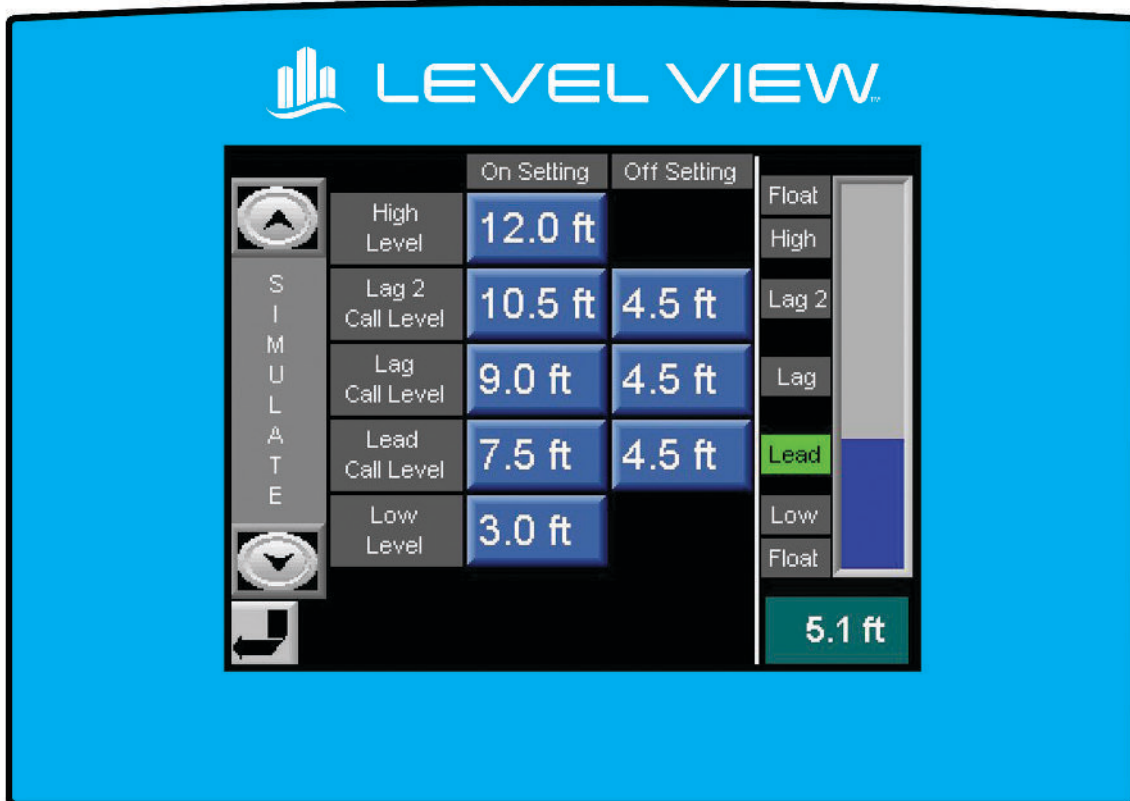



# TABLE OF CONTENTS

Introduction and Specifications .....	1
Main Screen .....	2
Data log .....	3
Alarms .....	3
Active Alarms .....	4
Alarm History.....	5
Setup.....	7
Level Setup .....	8
Pump Down Mode .....	8
Tank Cleanout Mode.....	10
Pump Up Mode .....	12
VFD Setup.....	13
Sensor Setup .....	14
Timers Setup.....	15
Flow Setup .....	15
Pump Amps Setup .....	16
Jam Detection Setup.....	17
System Setup.....	19
Pump Data Screen.....	21
Level View™ Power up Screen .....	22
I/O Terminal Configuration.....	22
I/O Table .....	23
Electrical Wiring Diagrams .....	24
Dimensions and Mounting .....	26
DIP Switch Settings & I/O Module Jumper .....	27
Level View™ Controller Setpoints List.....	28

# WARNINGS

Failure to read and understand the information provided in this manual may result in personal injury or death, damage to the product or product failure. Please read each section in its entirety and be sure you understand the information provided in the section and related sections before attempting any of the procedures or operations given.

<p>Failure to follow these precautions could result in serious injury or death. Keep these instructions with warranty after installation. This product must be installed in accordance with National Electrical Code, ANSI/NFPA 70 so as to prevent moisture from entering or accumulating within the controller housing.</p>	
<p><b>⚠ WARNING</b></p> 	<p><b>ELECTRICAL SHOCK HAZARD</b></p> <p>A qualified service person must install and service this product according to applicable codes and electrical schematics. Disconnect power prior to servicing any equipment with the Level View™ controller.</p>
<ul style="list-style-type: none"><li>• Do not connect power to this equipment if it has been damaged or has any missing parts.</li><li>• The Level View™ contains no serviceable parts; do not attempt to repair this equipment.</li><li>• Do not install in areas with: excessive or conductive dust, corrosive or flammable gas, moisture or rain, excessive head, regular impact shocks, or excessive vibration.</li></ul>	
<p><b>⚠ WARNING</b></p> 	<p><b>EXPLOSION OR FIRE HAZARD</b></p> <p>Do not use this product with flammable liquids. Do not install in hazardous locations as defined by National Electrical Code, ANSI/NFPA 70.</p>

# INTRODUCTION & SPECIFICATIONS

Congratulations, and thank you for your purchase of the Level View™ controller. This manual explains the features and operations of the Level View™ controller which was designed specifically for pump stations. It can be configured for pump up or pump down applications. It uses a level transducer with two (2) back up float switches.

## GENERAL

Duplex or triplex pump controller  
Pump up or pump down  
4-20mA level transducer with 2 back up floats  
(High + low) (external of controller)  
Pump amps monitoring with current transducer  
Pump flow monitoring  
Pump HOA selector switch in AUTO monitoring  
Pump fault monitoring  
Power loss monitoring  
Color touch display with easy navigation and intuitive setup  
Display resolution: 320 X 240 (QVGA)  
Colors: 65,536  
Display viewing area: 5.7”  
Auto-Reversing / Jam Detection Functionality  
Tank Cleanout Mode (Pump down only)

## CONTROLLER FEATURES

Level/flow monitoring  
Pump level in feet + bar graph  
Pump GPM (Using volumetric calculation with level transducer)  
Auto-Reversing / Jam Detection Functionality  
Tank Cleanout Mode (Pump down only)

## PUMP CONTROL AND PROTECTION

Automatic pump alternation  
Alternation can be forced to start a particular pump first every time  
Pump dry run protection (based on motor amps + timer) with current transducer  
Pump run indication  
Pump Amp indication (with current transducer)  
Constant or variable speed

## SYSTEM

24hrs data log + 7 days of historical data

- Gallons pumped for each pump
- Number of starts for each pump
- Run time for each pump

Real time clock  
Password protection (single level)  
Alarm log  
Level simulation

## ELECTRICAL SPECIFICATIONS

### Dedicated I/Os (see I/O table)

- 18 digital inputs
- 15 relay outputs (250 VAC, 3A Max.)
- 4 analog inputs (4-20mA, 14 bit resolution)
- 4 analog inputs (4-20mA, 12 bit resolution)

### Power

- 24 VDC (20.4 - 28.8 VDC)
- 270 mA@24 V + 130mA for I/O = 400mA max
- Optional battery backup

## ENVIRONMENT

Operational temperature 0 to 50°C (32 to 122°F)  
Storage temperature -20 to 60°C (-4 to 140°F)  
Relative Humidity (RH) 5% to 95% (non-condensing)

## COMMUNICATION

SCADA compatible  
Serial port: RS 485 Modbus RTU slave  
Optional cellular remote monitoring  
(PRIMEX™ PUMP WATCH™)  
Optional Ethernet card: Modbus TCP/IP server

## CERTIFICATION

UL / cUL / CE listed

# PROGRAMMING

## MAIN SCREEN

The **Main** screen gives the operator an overview of the lift station status.

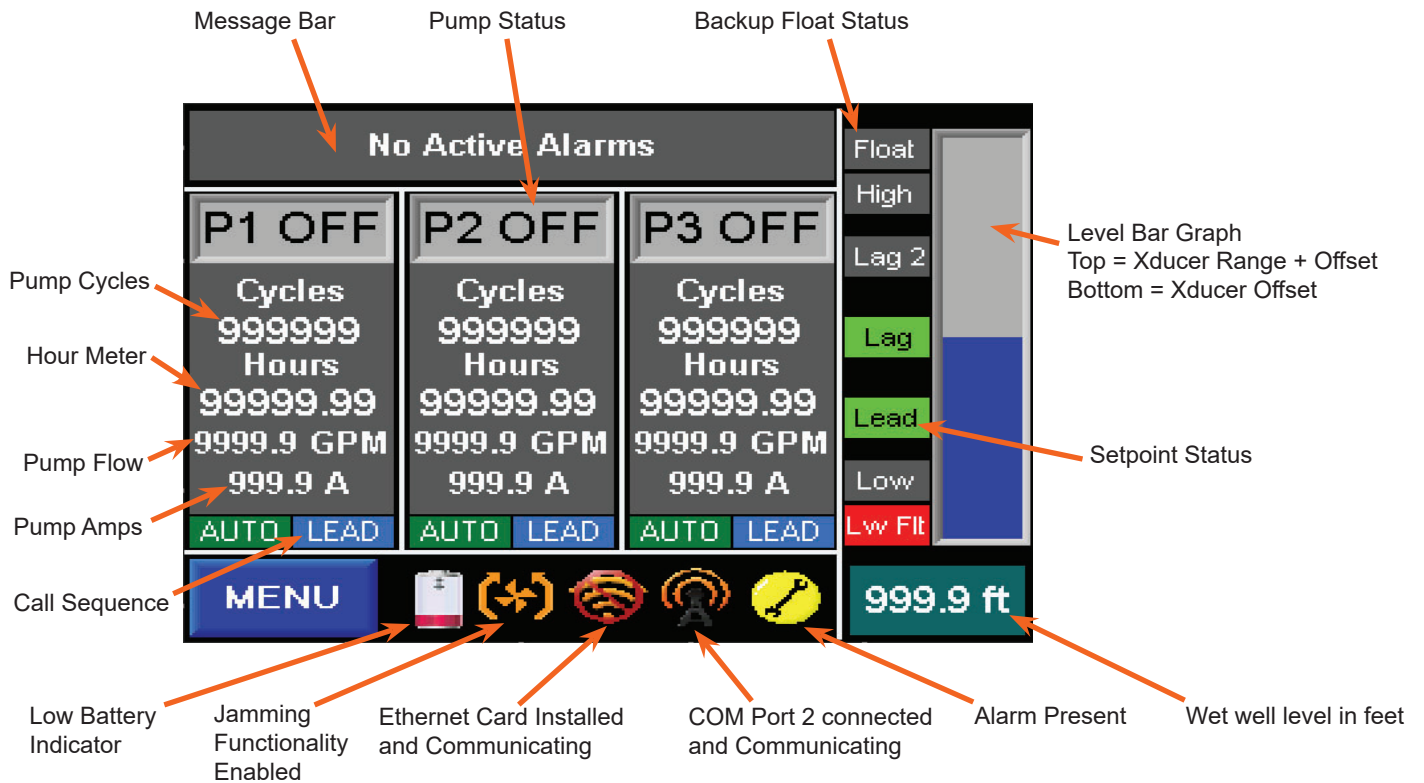

## ACCESSING THE MENU SCREEN

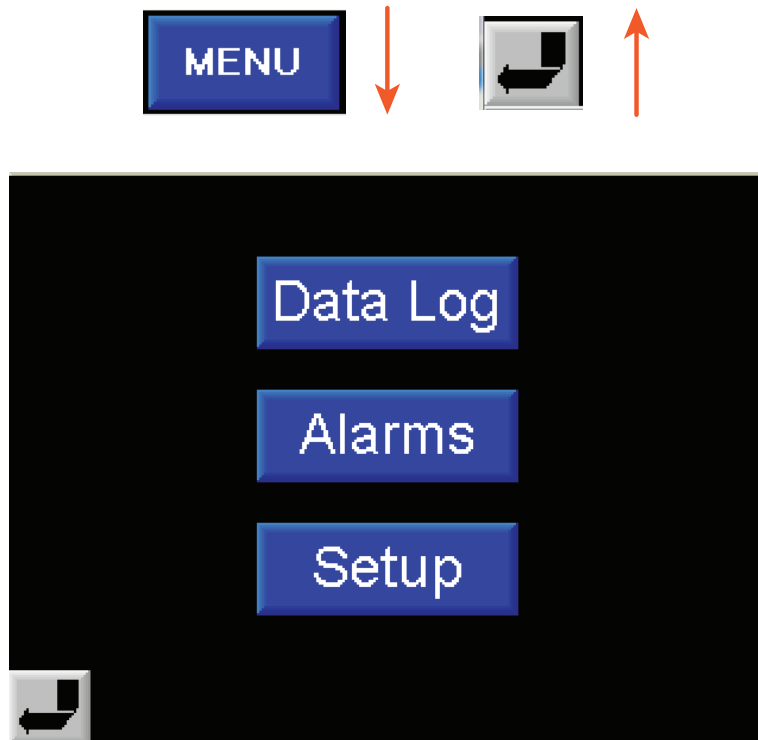

## DATA LOG

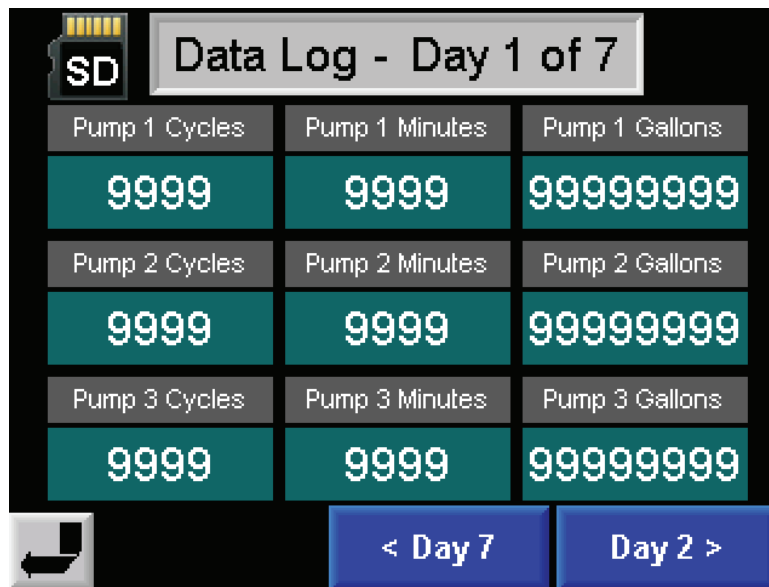

The screenshot shows a 'Data Log - Day 1 of 7' screen. At the top left is an SD card icon. The title 'Data Log - Day 1 of 7' is in a grey box. Below is a table with three rows for Pump 1, Pump 2, and Pump 3. Each row has three columns: Cycles, Minutes, and Gallons. The values are all '9999' or '99999999'. At the bottom, there are navigation buttons: '< Day 7' and 'Day 2 >'. A small icon is in the bottom left corner.

Pump 1 Cycles	Pump 1 Minutes	Pump 1 Gallons
9999	9999	99999999
Pump 2 Cycles	Pump 2 Minutes	Pump 2 Gallons
9999	9999	99999999
Pump 3 Cycles	Pump 3 Minutes	Pump 3 Gallons
9999	9999	99999999

The Level View™ controller will log daily station data for 7 days including today's data since midnight. Pump 1, Pump 2, & Pump 3 cycles/day, runtime/day, gallons/day are recorded. Day 1 through Day 7 can be accessed by using the navigation buttons. Day 1 represents the data logged today since 0:00 (midnight). Day 2 through Day 7 each holds values accumulated in a 24 hour period (midnight to midnight)

## ALARMS

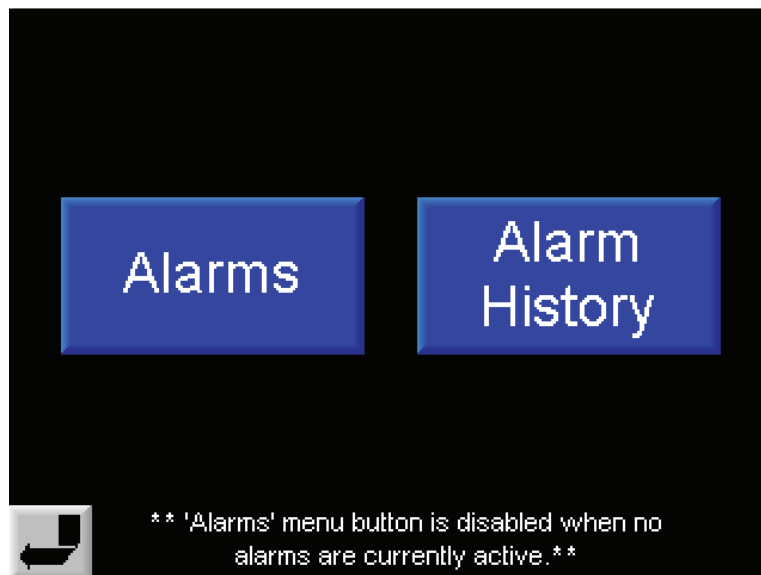

If the **Alarms** button is touched, the **Pending Alarms** screen will be opened, letting you see any currently active alarms. If the **Alarm History** button is touched, the **Alarm History** screen will be opened.

## ACTIVE ALARMS

This screen will display the total number of active alarms. By pressing the magnifying glass, the details of any active alarm can be displayed. To return to the **Active Alarms** screen, press the **ESC** button.

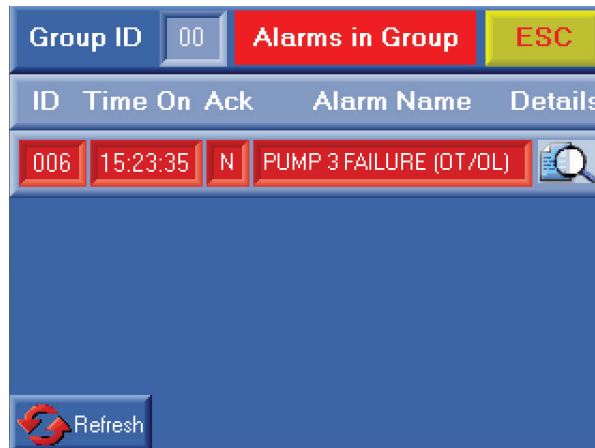



This screen will display the alarms that have occurred. Pressing the **Refresh** button will only display active alarms. **Time On** indicates the time the alarm occurred.



If you touch the magnifying glass, the details of any active alarm will be displayed. To return to the **Pending Alarm** screen, press the **ESC** button.



## ALARM HISTORY

The Alarm History screen shows the most recent alarm, along with: when it occurred, when it returned to normal, the duration of the event, and when it was reset. Use the  button to look at the second most recent. The  and  keys can be used to scroll through all of the alarms stored in the **Alarm History** log. To return to the **Alarm** menu, touch the **ESC** button.

Priority	Low	<b>Alarm History</b>	<b>ESC</b>
Group	00	General Collection	
ID	005	PUMP 2 FAILURE (OT/OL)	
Trigger Rise Time	09/10/14 13:41	<b>Duration</b>	
Trigger Fall Time	09/10/14 14:28	00:46:29	
Ack. Time	01/01/0 00:00	00:00:00	
Reset Time	01/01/0 00:00	00:00:00	
			

Time and date of alarm occurrence & deactivation + duration

Possible alarms include:

#	DISPLAY	DEFINITION	FIX
0	<b>LOW LEVEL XDCR</b>	Level in the wet well has fallen below the Low Level Set point	Check wet well & check transducer
1	<b>HIGH LEVEL XDCR</b>	Level in the wet well has exceeded the High Level Set point	Check pump operation, check in-flow, check level transducer
2	<b>LOW LEVEL FLOAT</b>	Low level float is OFF (down)	Check float & check transducer
3	<b>HIGH LEVEL FLOAT</b>	High level float is ON (up)	Check pumps operation, check in-flow, check level transducer
4	<b>P1 FAILURE (OT/OL)</b>	Pump 1 Overload trip or Over Temp trip	Check voltage, pump clogging or wear
5	<b>P2 FAILURE (OT/OL)</b>	Pump 2 Overload trip or Over Temp trip	Check voltage, pump clogging or wear
6	<b>P3 FAILURE (OT/OL)</b>	Pump 3 Overload trip or Over Temp trip	Check voltage, pump clogging or wear
7	<b>P1 SEAL FAILURE</b>	Pump 1 seal failure	Check pump seal
8	<b>P2 SEAL FAILURE</b>	Pump 2 seal failure	Check pump seal
9	<b>P3 SEAL FAILURE</b>	Pump 3 seal failure	Check pump seal
10	<b>BACKUP FLOAT MODE</b>	Backup float mode is active (High float tripped)	Check transducer operation
11	<b>POWER/PHASE FAILURE</b>	Power loss or Phase loss to the control panel	Check incoming power and phase monitor
12	<b>XDCR OPEN ALARM</b>	Transducer signal is less than 4mA	Check transducer connection, check transducer and vent tube
13	<b>PUMP 1 HIGH CURRENT</b>	Pump amps higher than expected for time delay	Check voltage, pump clogging or wear
14	<b>PUMP 2 HIGH CURRENT</b>	Pump amps higher than expected for time delay	Check voltage, pump clogging or wear
15	<b>PUMP 3 HIGH CURRENT</b>	Pump amps higher than expected for time delay	Check voltage, pump clogging or wear
16	<b>PUMP 1 DRY RUN</b>	Pump amps lower than expected for time delay	Check transducer, check low level float, check pump
17	<b>PUMP 2 DRY RUN</b>	Pump amps lower than expected for time delay	Check transducer, check low level float, check pump
18	<b>PUMP 3 DRY RUN</b>	Pump amps lower than expected for time delay	Check transducer, check low level float, check pump
19	<b>PANEL INTRUSION</b>	The control panel door has been opened	
20	<b>LOW BATTERY</b>	The controller battery is low	Change battery with power on controller. Power cycle controller to reset screen indicator.
21	<b>PUMP 1 JAM ALARM</b>	Pump 1 has detected a jam (high current)	Check parameters in "Jam Detection Setup" screens. If issue persists, pump is jammed/ clogged and needs to be removed to clean.
22	<b>PUMP 1 RAPID JAM ALARM</b>	Pump 1 has detected a rapid jam (immediate blockage)	Check parameters in "Jam Detection Setup" screens. If issue persists, pump is jammed/ clogged and needs to be removed to clean.
23	<b>PUMP 2 JAM ALARM</b>	Pump 2 has detected a jam (high current)	Check parameters in "Jam Detection Setup" screens. If issue persists, pump is jammed/ clogged and needs to be removed to clean.
24	<b>PUMP 2 RAPID JAM ALARM</b>	Pump 2 has detected a rapid jam (immediate blockage)	Check parameters in "Jam Detection Setup" screens. If issue persists, pump is jammed/ clogged and needs to be removed to clean.
25	<b>PUMP 3 JAM ALARM</b>	Pump 3 has detected a jam (high current)	Check parameters in "Jam Detection Setup" screens. If issue persists, pump is jammed/ clogged and needs to be removed to clean.
26	<b>PUMP 3 RAPID JAM ALARM</b>	Pump 3 has detected a rapid jam (immediate blockage)	Check parameters in "Jam Detection Setup" screens. If issue persists, pump is jammed/ clogged and needs to be removed to clean.

# SETUP

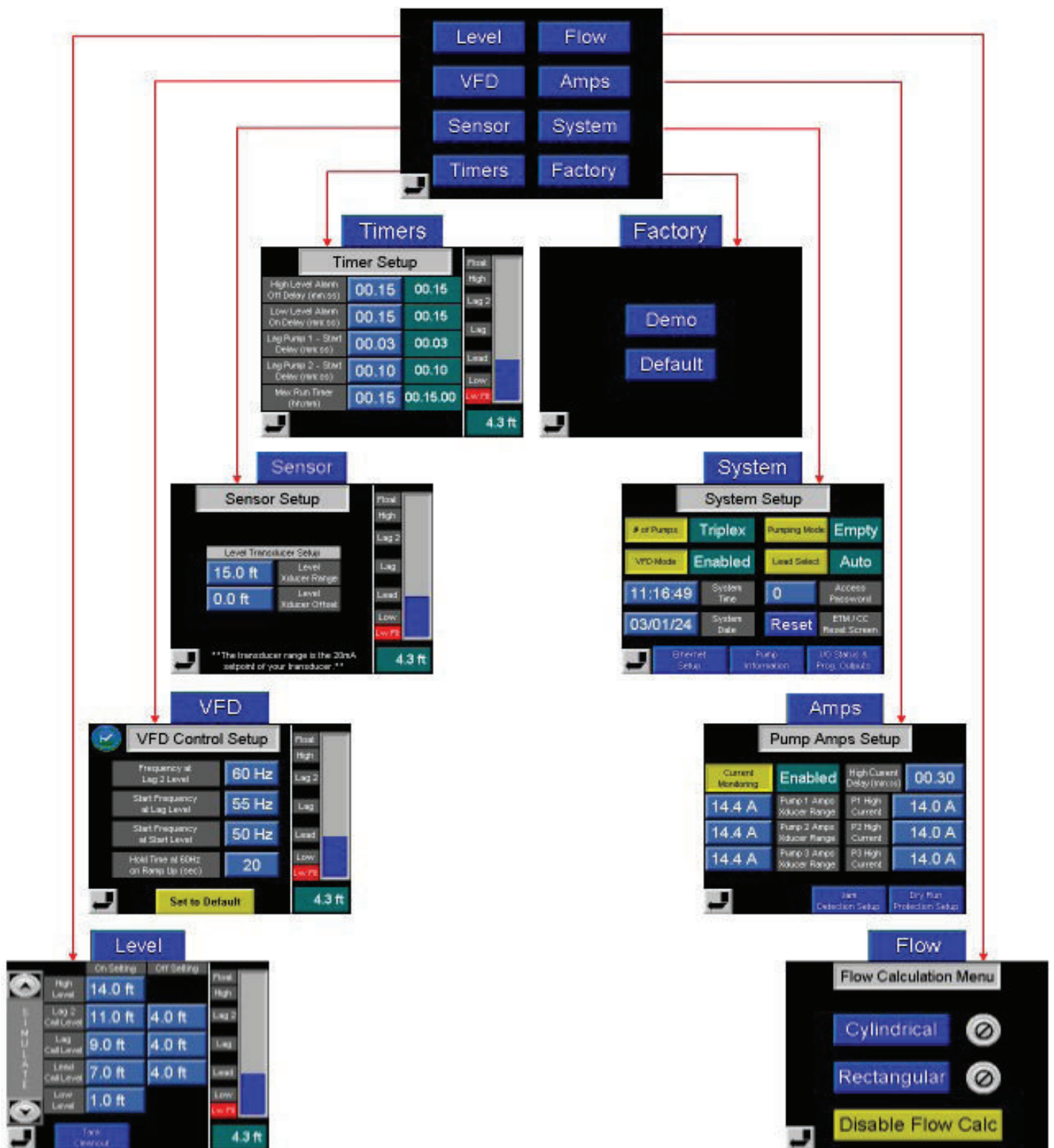

## LEVEL SETUP

The **Level Setup** screen is where the level set-points can be monitored and modified.

## PUMP DOWN MODE



To change any of the set-points, simply touch the display for the set-point and a keyboard will appear. Enter the new value using the keyboard and press the **Return** key. The new value entered will replace the previously displayed value. The following set-points can be modified from this screen:

<b>Low Level</b>	When the level falls below this set-point, the <b>Low Level Alarm on Delay (mm:ss)</b> timer set on the <b>Timers</b> screen will start. After the configured amount of time has elapsed, the <b>LOW LEVEL XDCR</b> alarm will be set. This alarm condition will automatically reset once the level rises above this set-point.
<b>Lead Call Level</b>	<b>OFF:</b> When the level is pumped below this set-point, the <b>Lead</b> pump will turn off. <b>ON:</b> When the level rises above this level, the <b>Lead</b> pump will be called to start.
<b>Lag Call Level</b>	<b>OFF:</b> When the level is pumped below this set-point, the <b>Lag</b> pump will turn off. <b>ON:</b> When the level rises above this level, the <b>Lag</b> pump will be called to start.
<b>Lag 2 Call Level</b>	<b>OFF:</b> When the level is pumped below this set-point, the <b>Lag 2</b> pump will turn off. <b>ON:</b> When the level rises above this level, the <b>Lag 2</b> pump will be called to start. These set-points are only accessible in TRIPLEX pump operation mode.
<b>High Level</b>	When the level rises above this level, then the <b>HIGH LEVEL XDCR</b> alarm will be set. Once the level falls below this set-point, the <b>High Level Alarm Off Delay (mm:ss)</b> timer on the <b>Timers</b> screen will start. After the configured amount of time has elapsed, the alarm condition will reset.

This screen also has two buttons which can be used to force the level reading in the controller either up or down. This is used to simulate the level rising or falling for testing. To enter Level Simulation mode, hold the up or down arrow for 5 seconds. If the **Up Simulate** button is pressed, the internal level in the controller will rise. This can be used to confirm that the pumps turn ON at the proper point. If the **Down Simulate** button is pressed, then the level will fall, confirming that the pumps turn OFF or that the low level will come on. Shortly after releasing the button (5 seconds) the system will return to normal and read the actual level. Use the **Return** button in the lower left corner of this screen to return to the **Setup** screen.

**Back up float switch operation:** Two back up floats are strongly recommended. They need to be wired to control the pumps independently of the Level View™ controller. The float inputs into the Level View™ controller are for alarm monitoring purposes only, not for pump control.

**High Level Float:** All pumps will run when activated until the level drops below the Low Level floats and will also activate the alarm beacon and horn. The High Level float switch is typically set above the High Level transducer set point.

**Low Level Float:** If the level drops below the Low Level float switch, it will stop any pump operation in automatic mode. The purpose of the Low Level float switch is to protect the pumps against damage resulting from a dry run condition. The Low Level float switch is typically set below the Low Level transducer set point.

## TRANSDUCER/FLOAT SWITCH INSTALLATION

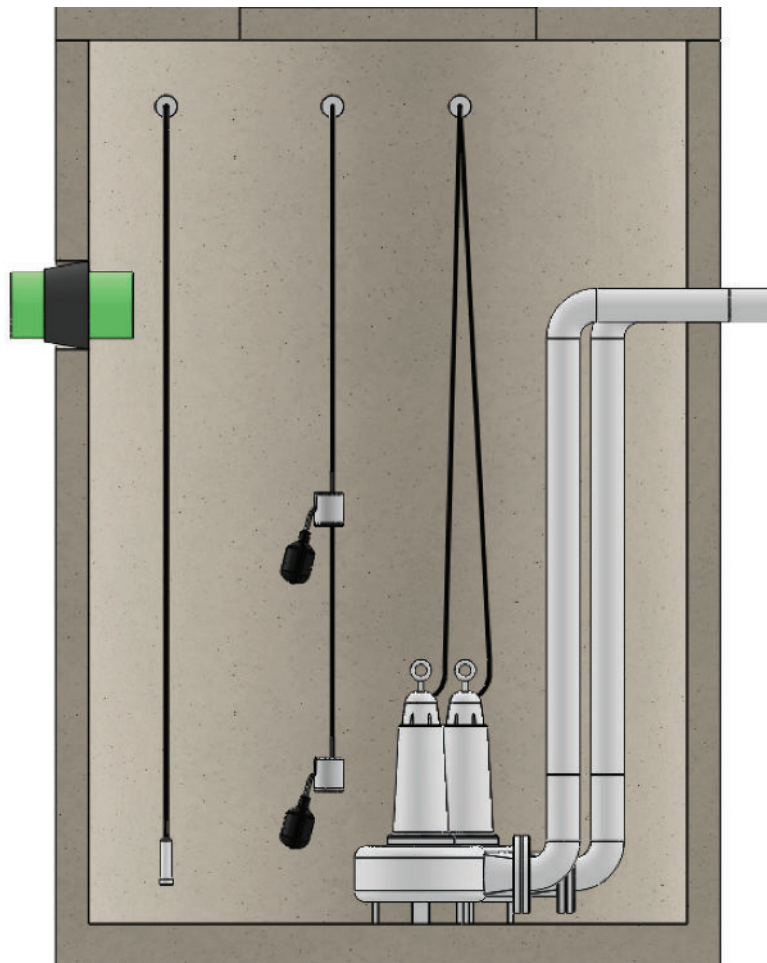

# Tank Cleanout Mode:

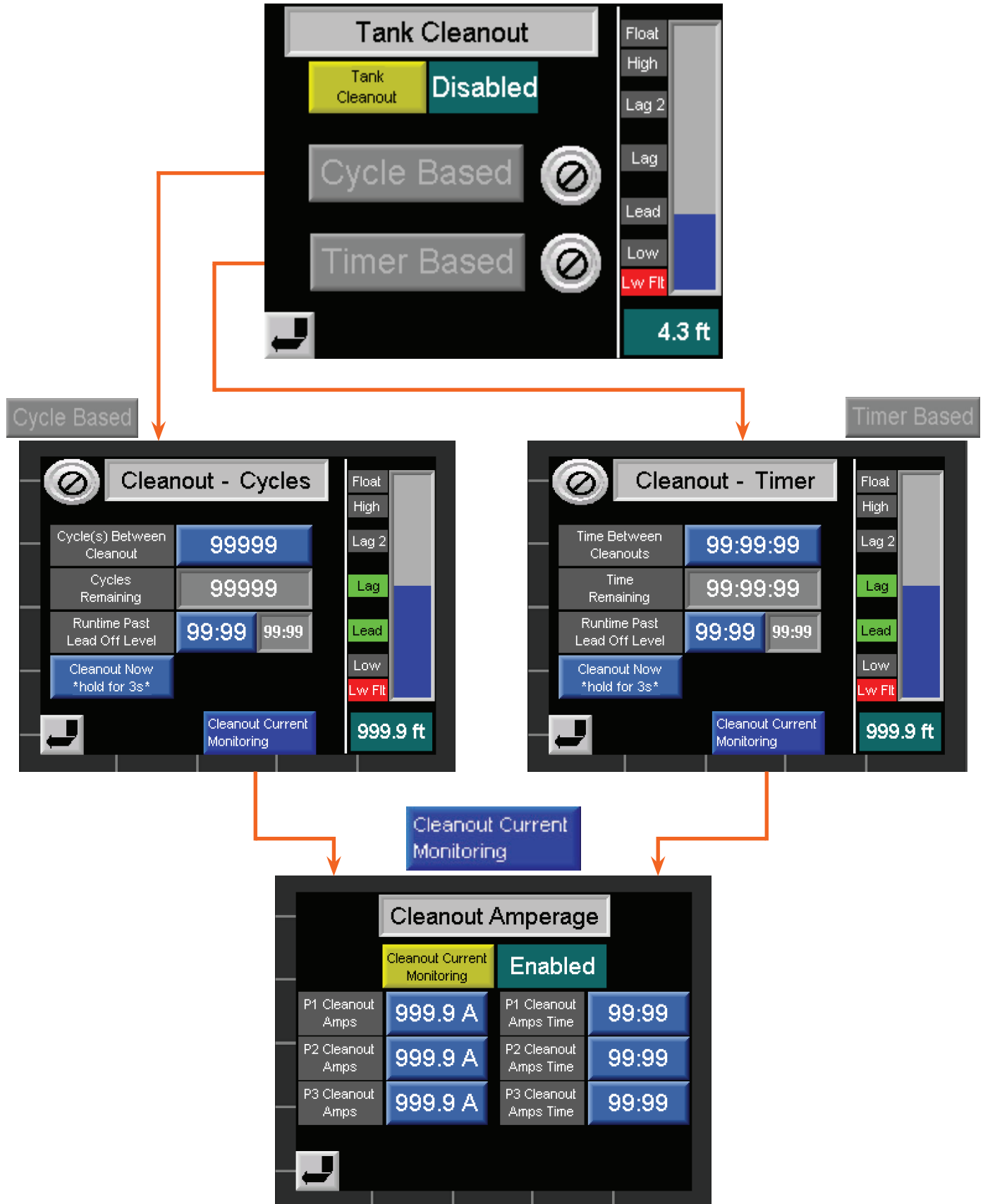

**Tank Cleanout** is used to pump down past the Lead Off Level. It is only available in Pump Down mode. The purpose is to prevent buildup in the wet well or to help clear debris lower in the tank by pumping lower than the Lead Off level. There is 2 modes of operation for **Tank Cleanout**. Cycle based and Timer based.

**Cycle based:** Increments a counter every time the Lead pump is called. Once that counter is equal to the setting “Cycle(s) Between Cleanout” on the LevelView then the system enters **Tank Cleanout mode**.

**Timer based:** Starts a timer “Time Between Cleanouts”, regardless of whether the pumps are running or not. Once complete, upon the next Lead pump call the system will enter **Tank Cleanout mode**.

In both modes the pumps are called for a programmable amount of time past the Lead Off Level. Shown as “Runtime Past Lead Off Level”.

### Process description:

**Tank Cleanout** is Enabled and the cycles or timer requirements are satisfied to enter the system into **Tank Cleanout Mode**. Once active, the Lead Pump turns on. All subsequent pumps are called based on their own on delays set in the **Timers** screen. All available pumps are called at full speed (if VFD is enabled) and run past the Lead Off Level for the set amount of time.

While the **Tank Cleanout** is active, the Low Float, Low Level, and Level Open Sensor Alarms are suppressed. This is to make sure alarms do not trigger when the pumps are intending to pump down the wet well. To facilitate this, programmable output relay 4 (actual output 12) is set to “Tank Cleanout Active” when the **Tank Cleanout** is enabled. This can then be used in external circuitry to bypass entering backup mode or triggering faults.

### Cleanout Current Monitoring:

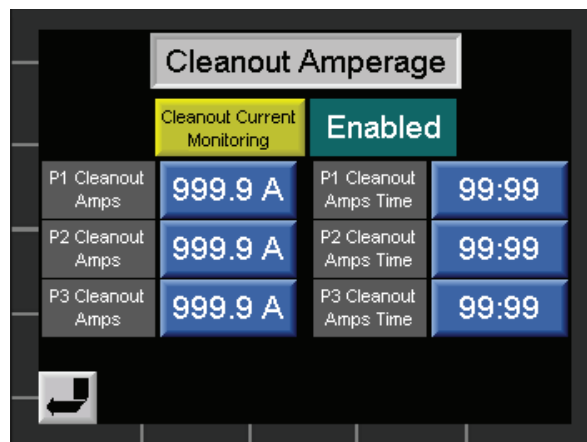

Cleanout Amperage			
Cleanout Current Monitoring		Enabled	
P1 Cleanout Amps	999.9 A	P1 Cleanout Amps Time	99:99
P2 Cleanout Amps	999.9 A	P2 Cleanout Amps Time	99:99
P3 Cleanout Amps	999.9 A	P3 Cleanout Amps Time	99:99

This is an additional check while doing the **Tank Cleanout** process. This feature can be enabled and the system will run down to the specified motor current or below for the specified amount of time. This is in addition to the existing pump down timer. If the motor current is not met within the “Runtime Past Lead Off Level” setting then the **Tank Cleanout** is stopped as normal. If the motor current is below the “Px Cleanout Amps” for the specified amount of time then the **Tank Cleanout** process is stopped before the “Runtime Past Lead Off Level” timer is complete. This allows the system to exit **Tank Cleanout Mode** quicker.

## PUMP UP MODE

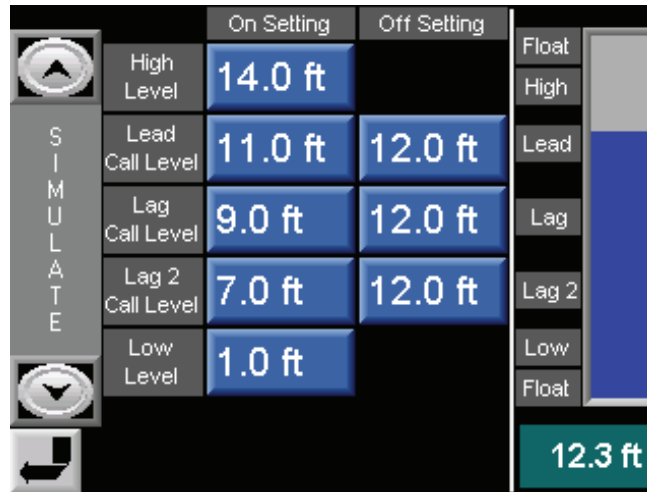

To change any of the set-points, simply touch the display for the set-point and a keyboard will appear. Enter the new value using the keyboard and press the **Return** key. The new value entered will replace the previously displayed value. The following set-points can be modified from this screen:

<b>Low Level</b>	When the level falls below this level, then the <b>LOW LEVEL XDCR</b> alarm will be set. Once the level rises above this set-point, the <b>Low level Alarm Off Delay (mm:ss)</b> timer on the <b>Timers</b> screen will start. After the configured amount of times has elapsed, the alarm condition will reset.
<b>Lead Call Level</b>	<b>OFF:</b> When the level is pumped above this set-point, the <b>Lead</b> pump will turn off. <b>ON:</b> When the level falls below this level, the <b>Lead</b> pump will be called to start.
<b>Lag Call Level</b>	<b>OFF:</b> When the level is pumped above this set-point, the <b>Lag</b> pump will turn off. <b>ON:</b> When the level falls below this level, the <b>Lag</b> pump will be called to start.
<b>Lag 2 Call Level</b>	<b>OFF:</b> When the level is pumped above this set-point, the <b>Lag 2</b> pump will turn off. <b>ON:</b> When the level falls below this level, the <b>Lag 2</b> pump will be called to start. These set-points are only accessible in TRIPLEX pump operation mode.
<b>High Level</b>	When the level rises above this set-point, the <b>High Level Alarm On Delay (mm:ss)</b> timer set on the <b>Timers</b> screen will start. After the configured amount of time has elapsed, the <b>HIGH LEVEL XDCR</b> alarm will be set. This alarm condition will automatically reset once the level falls below this set-point.

This screen also has two buttons which can be used to force the level reading in the controller either up or down. This is used to simulate the level rising or falling for testing. To enter Level Simulation mode, hold the up or down arrow for 5 seconds. If the **Up Simulate** button is pressed, the internal level in the controller will rise. This can be used to confirm that the pumps turn ON at the proper point. If the **Down Simulate** button is pressed, then the level will fall, confirming that the pumps turn OFF or that the low level will come on. Shortly after releasing the button (5 seconds) the system will return to normal and read the actual level. Use the **Return** button in the lower left corner of this screen to return to the **Setup** screen.

**Back up float switch operation:** Two back up floats are strongly recommended. They need to be wired to control the pumps independently of the Level View™ controller. The float inputs into the Level View™ controller are for alarm monitoring purposes only, not for pump control.

**High Level Float:** All pumps will run when activated until the level drops below the Low Level floats and will also activate the alarm beacon and horn. The High Level float switch is typically set above the High Level transducer set point.

**Low Level Float:** If the level drops below the Low Level float switch, it will stop any pump operation in automatic mode. The purpose of the Low Level float switch is to protect the pumps against damage resulting from a dry run condition. The Low Level float switch is typically set below the Low Level transducer set point.

## VFD SETUP

The Level View™ controller is capable of pump speed control based on level.

Parameter	Value
Frequency at Lag 2 Level	60 Hz
Start Frequency at Lag Level	55 Hz
Start Frequency at Start Level	50 Hz
Hold Time at 60Hz on Ramp Up (sec)	20

Level Indicator: 4.1 ft

**Hold Time at 60Hz on Ramp Up (sec):** When the pump starts, it will automatically ramp up to full speed (60Hz) for the number of seconds set in this parameter. When the timer times out, the VFD will follow the speed curve set by the other parameters.

**Start Frequency at Start Level:** This parameter determines the pump speed at the Lead Pump ON Level. If the level does not rise above the Lead Pump ON level, the pump speed will not change. The pump will ramp down and stop as the level drops below the Lead Pump OFF level.

**Example:** Hold time = 10 sec, and Start Frequency = 50Hz

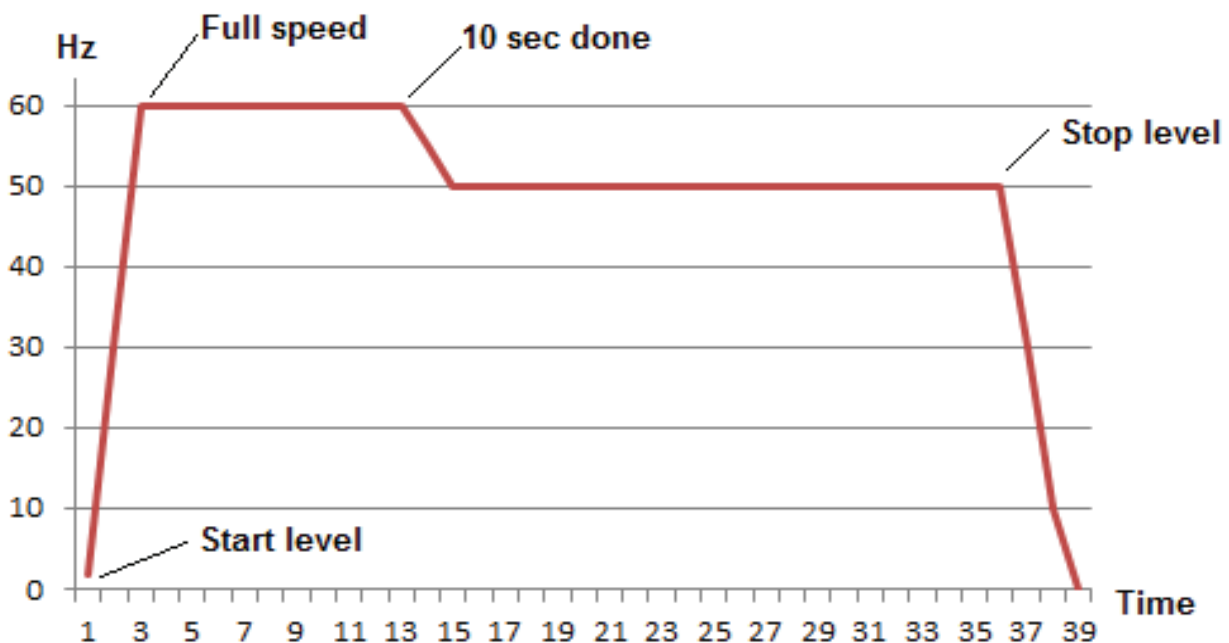

**Start Frequency at Lag Level:** This parameter sets the pump speed at the Lag Pump ON level. As the level rises above the Lag Pump ON level, the second pump starts and runs at the same speed as the lead pump until it reaches the Lag Pump OFF level and stops.

**Example:** Hold time = 10 sec, and Start Frequency = 50Hz, Start Frequency at Lag Level = 58Hz

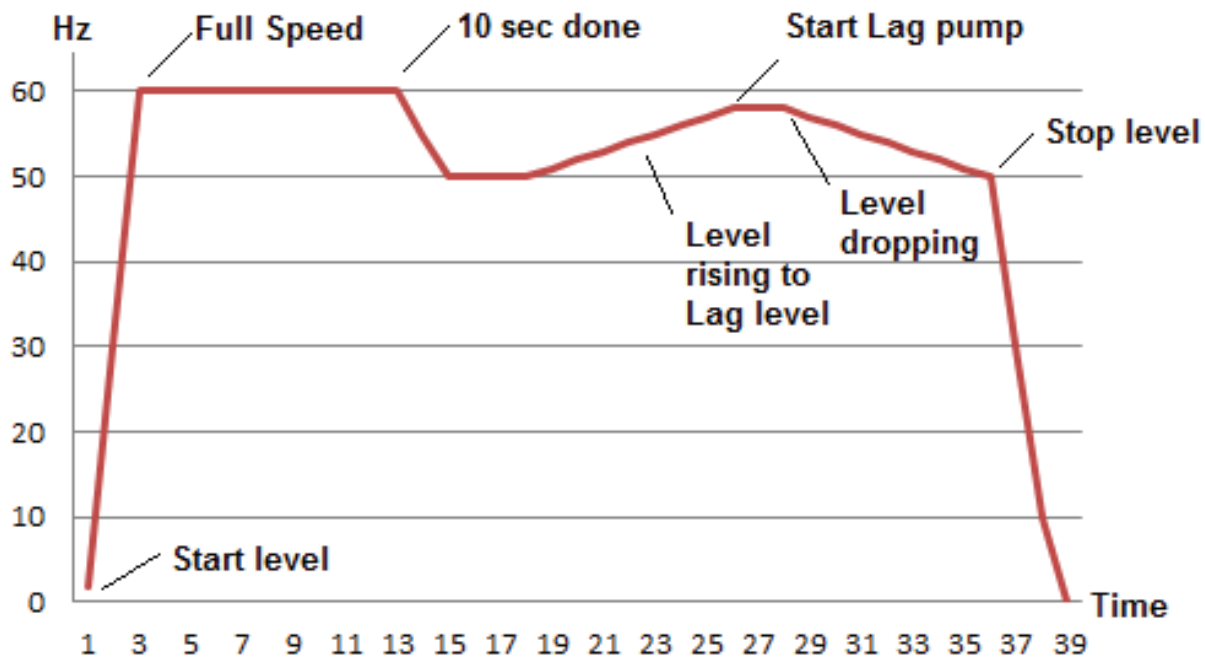

**Start Frequency at Lag 2 Level:** This parameter sets the pump speed at the Lag 2 Pump ON level. As the level rises above the Lag 2 Pump ON level, the third pump starts and runs at the same speed as the lead + lag pump until it reaches the Lag 2 Pump OFF level and stops.

## SENSOR SETUP

The level transducer parameters are entered on this screen.

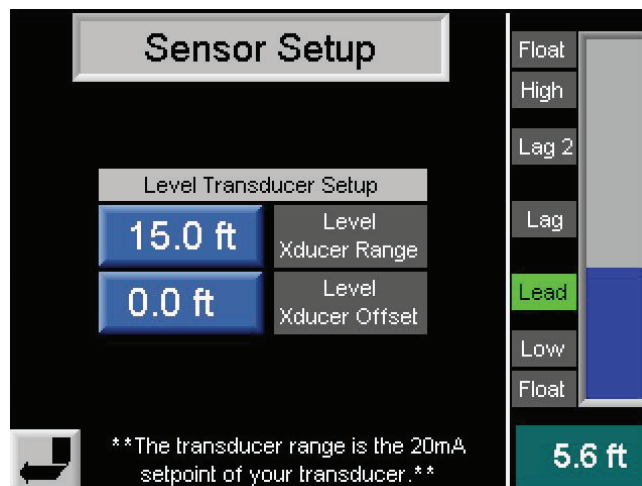

## Level Transducer

To configure the controller to match the **Level Transducer**, touch the **Level Xducer Range** button. Using the pop-up keyboard, enter the maximum range value of the transducer. This is the water level at which the transducer will output 20mA.

Example: 0-10 psi range level transducer = 0-23.0 ft. (1 psi = 2.30 ft.) Set 20mA = 23.0 ft.  
Some transducers are already calibrated in feet. (Max value for 20mA is 999.9 ft.)

When using a submersible pressure transducer, 0.0 ft. represents the level at the bottom of the transducer and not the wet well. If the transducer is mounted 2.0 feet off the bottom of the tank, set the Level Xducer Offset to: 2.0 ft.

## TIMERS SETUP

Timer Setup			Float
High Level Alarm Off Delay (mm:ss)	00.15	00.15	High
Low Level Alarm On Delay (mm:ss)	00.15	00.15	Lag 2
Lag Pump 1 - Start Delay (mm:ss)	00.03	00.03	Lag
Lag Pump 2 - Start Delay (mm:ss)	00.10	00.10	Lead
Max Run Timer (hh:mm)	00.15	00.15.00	Low
			Lw Fil
			4.3 ft

Timer Setup			Float
High Level Alarm On Delay (mm:ss)	99:99	99:99	High
Low Level Alarm Off Delay (mm:ss)	99:99	99:99	Lag 2
Lag Pump 1 - Start Delay (mm:ss)	99:99	99:99	Lag
Lag Pump 2 - Start Delay (mm:ss)	99:99	99:99	Lead
Max Run Timer (hh:mm)	99:99	99:99:99	Low
			Lw Fil
			999.9 ft

Depending on what Pumping Mode the controller is set to will determine what screen is displayed.

**High Level Alarm Off Delay (mm:ss) [Pump Down]** - Delay when to turn off High Level Alarm

**High Level Alarm On Delay (mm:ss) [Pump Up]** - Delay when to turn on High Level Alarm

**Low Level Alarm On Delay (mm:ss) [Pump Down]** - Delay when to turn on Low Level Alarm

**Low Level Alarm Off Delay (mm:ss) [Pump UP]** - Delay when to turn off Low Level Alarm

**Lag Pump 1 - Start Delay (mm:ss)** - Delay for Lag 1 Pump Call

**Lag Pump 2 - Start Delay (mm:ss)** - Delay for Lag 2 Pump Call (Disabled if not in a Triplex system)

**Max Run Timer (hh:mm)** - Max run time of one pump running on it's own. If this time is exceeded, the Lead pump will be shut off and the next available pump in the alternation cycle will be called as Lead. This is to try and run the pumps as even as possible in systems that do not generally pump down past the Lead Off Level.

## FLOW SETUP

The controller will calculate the pump GPM using time and the water level. In order for the controller to do this, it must know the wet well configuration and dimensions. If the tank is cylindrical, press the circle next to the **Cylindrical** button to set a check mark. If the tank is rectangular, press the circle next to the **Rectangular** button to set a check mark. To disable flow calculation, press the **Disable Flow Calc** button to uncheck both well types. If the well is cylindrical, touch the Cylindrical button. If the well is rectangular, touch the Rectangular button.

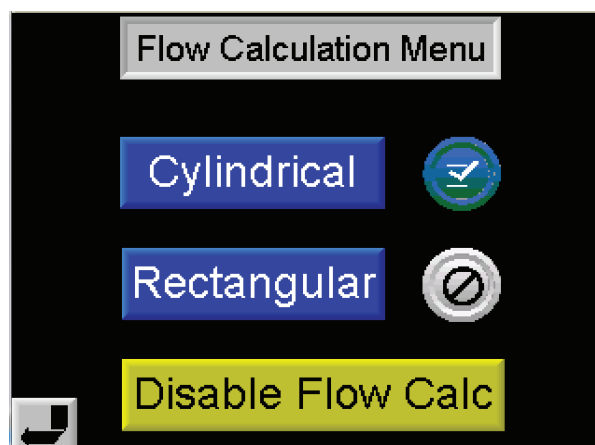

If the tank is cylindrical, enter the tank diameter using the (d) tank diameter display.

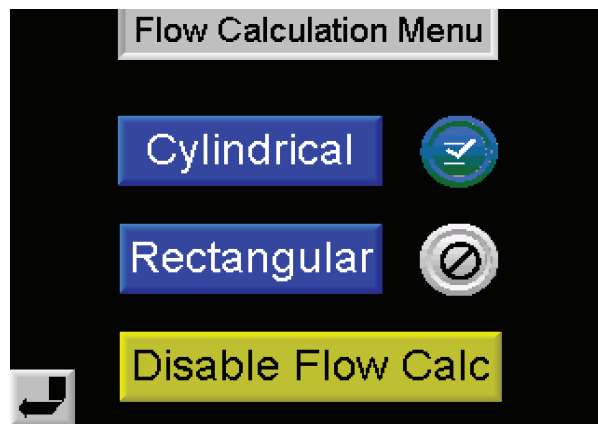

If the tank is rectangular, enter the tank dimensions using the (a) and (b) display buttons.

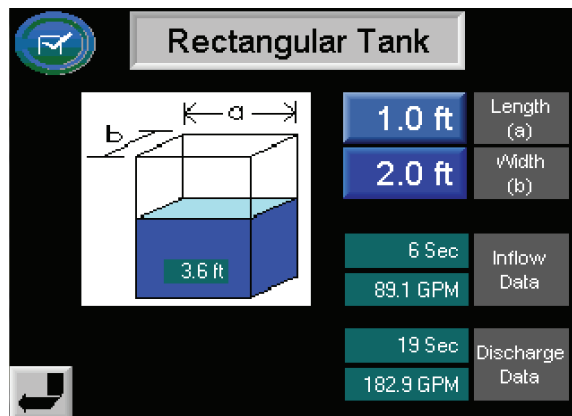

## PUMP AMPS SETUP

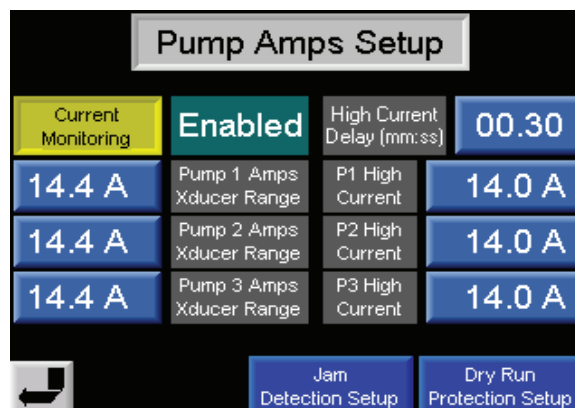

The Level View™ controller uses a current transducer for each pump. The measuring range of the current transmitter is typically listed on the transducer. The default unit has a 0-100A range.

### Current Transducers

To configure the controller to match the current transducer, touch the **Pump X Amp Range** button. Using the pop-up keyboard, enter the maximum range value of the transducer. This is the amp value at which the transducer will output 20mA.

### High Current Monitoring

When **Enabled**, the **Current Monitoring** uses the pump amps measurement to determine whether a pump is overloading due to a clog, low voltage, or other changing conditions. Set this value 20% higher or more than the normal running amps. This function does not stop the pump, it only generates an alarm.

## Jam Detection Setup:

Pump 1 Jam Setup			
Jam Monitoring	Enabled	Jam Clear time (mm:ss)	00.30
6.3 A	Pump Full Load Amps	Jams Before Fault	2
120 %	Normal Trip % 7.6 A	Initial Rev. time (mm:ss)	00.04
00.05	Normal Trip Delay (mm:ss)	Coast Rev to Fwd (mm:ss)	00.02
130 %	Rapid Trip % 8.2 A	Coast Fwd time (mm:ss)	00.02
		< Pump 3	Pump 2 >

Pump 2 Jam Setup			
Jam Monitoring	Enabled	Jam Clear time (mm:ss)	00.30
6.3 A	Pump Full Load Amps	Jams Before Fault	2
120 %	Normal Trip % 7.6 A	Initial Rev. time (mm:ss)	00.04
00.05	Normal Trip Delay (mm:ss)	Coast Rev to Fwd (mm:ss)	00.02
130 %	Rapid Trip % 8.2 A	Coast Fwd time (mm:ss)	00.02
		< Pump 1	Pump 3 >

Pump 3 Jam Setup			
Jam Monitoring	Enabled	Jam Clear time (mm:ss)	00.30
6.3 A	Pump Full Load Amps	Jams Before Fault	2
120 %	Normal Trip % 7.6 A	Initial Rev. time (mm:ss)	00.04
00.30	Normal Trip Delay (mm:ss)	Coast Rev to Fwd (mm:ss)	00.02
130 %	Rapid Trip % 8.2 A	Coast Fwd time (mm:ss)	00.02
		< Pump 2	Pump 1 >

Parameter	Range	Description
Pump Full Load Amps	0 - Pump 1, 2, or 3 Amps Xducer Range set on Pump Amps Setup screen.	Set to the Full load amperage of the installed pump.
Normal Trip %	100% - calculated percentage equal to Pump 1, 2, or 3 Amps Xducer Range.	Set to normal trip % value. Note VFD limitations when setting to not overload VFD.
Normal Trip Delay	0s - 59min:59sec	Amount of time current must be above the Normal Trip % until a jam is detected.
Rapid Trip %	100% - calculated percentage equal to Pump 1, 2, or 3 Amps Xducer Range.	Rapid trip is a 1s delay trip used if a massive blockage occurs in the pump. This faults out immediately rather than attempting to reverse. Note VFD limitations when setting to not overload VFD.
Jam Clear Time	0s - 59min:59sec	Time pump is running forward without detecting any new jams to clear the jam counter. Time until system is considered jam-free.
Jams Before Fault	0 - 99	Amount of times the jamming sequence runs until a normal trip alarm occurs. A rapid jam overrides this and faults out immediately if the value is reached. Normal Trip is set to a safe current that will not damage the pump if it encounters debris. Rapid Trip is set such that something is stuck in the pump and it must immediately be looked at.
Initial Rev. Time	0s - 59min:59sec	Time the pump is to run in the reverse direction to attempt to clear jam.
Coast Rev to Fwd	0s - 59min:59sec	Time the pump is stopped after running in the reverse direction before being called to run forward again.
Coast Fwd Time	0s - 59min:59sec	Time after normal jam is detected between stopping running forward and calling pump in reverse.

The Coast timers help prevent backlash in the pump by allowing it time to come to a complete stop before changing direction. These parameters also work in conjunction with the acceleration/deceleration values set in the VFD itself. Make sure the coast times are greater than or equal to the VFD acceleration/deceleration values to allow the pump proper time to stop safely.

## Pump Jamming Sequence Explanation:

When Enabled, the Jam Monitoring will monitor the selected pumps current during operation in two of the following scenarios.

### 1) Normal Trip Scenario

If the pump is running and the detected current is higher than the Normal Trip % current then the system shuts off that pump. The pump is shut off from running in the forward direction for the “Coast Fwd time”. Once that timer is complete, the pump is called in the reverse direction. It runs in the reverse direction for “Initial Rev time”. Once the time is complete, the pump is stopped from running in the reverse direction. It is stopped for the “Coast Rev to Fwd” time. Once complete, the pump is then called again in the forward direction. This process repeats until either the **Jam Clear Time** is met without any new jams or if the jam is detected more than the “Jams Before Fault” value. If the jam count is more than the “Jams Before Fault” then that pump is faulted out and pulled out of the alternation. An alarm will appear on the **Home** screen indicating the pump is jammed. This alarm can only be reset by pressing on the **Home** screen where indicated to reset the alarm. This is to acknowledge that the operator observed the high current scenario.

### 2) Rapid Trip Scenario

If the pump is running and has already detected one Normal Trip and the current detected is higher than the Rapid Trip % then the pump will be stopped immediately and removed from the alternation cycle. An alarm will appear stating there is a **Rapid Jam** on the pump. This alarm can only be reset by pressing on the **Home** screen where indicated to reset the alarm. This is to acknowledge that the operator observed the high current scenario.

To facilitate the ease of startup when utilizing the Jam Monitoring function, default outputs are automatically adjusted when jam monitoring is enabled.

When Pump 1 Jam Monitoring is enabled, Output 13 (Programmable Relay 5) is set to “Pump 1 Reverse Call”.

When Pump 2 Jam Monitoring is enabled, Output 14 (Programmable Relay 6) is set to “Pump 2 Reverse Call”.

When Pump 3 Jam Monitoring is enabled, Output 15 (Programmable Relay 7) is set to “Pump 3 Reverse Call”.

## Dry Run Protection

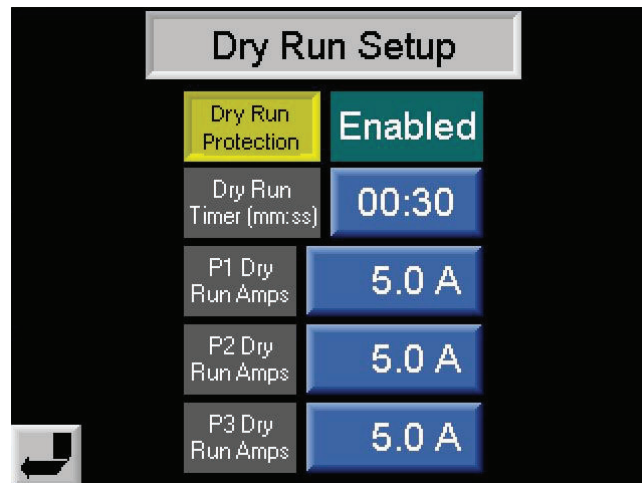

When **Enabled**, the **Dry Run Protection** uses the motor amps measurement to determine whether a pump is running dry (no load). For submersible pumps, set the **Pump Dry Run Amps** to 30% less than the amp draw during normal pumping operation. Please consult your pump manufacturer to confirm this value. If the amps drop below this value for longer than the **Dry Run Timer**, the controller will stop the pump and display a **Dry Run Fault**. The **Dry Run Timer** time is used to avoid nuisance tripping. If a pump trips on **Dry Run**, the next pump will be called to run. The **Dry Run Fault** automatically resets after two (2) minutes.

**Note:** If you are using VFDs, you must set the **Dry Run Amps** (A) value to 30% less of the normal running amps **at the minimum (lead start) frequency**.

## SYSTEM SETUP

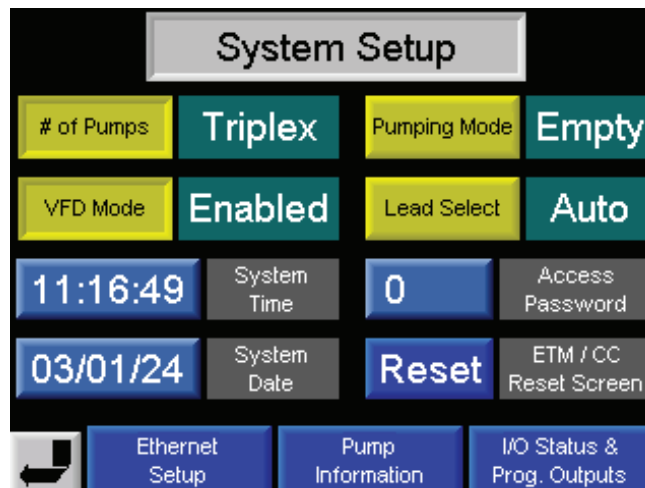

<b># of Pumps</b>	Set the number of pumps controlled
<b>VFD Mode</b>	Enable or disable VFD speed control
<b>System Time</b>	Set this to the current time of day (24 hour form)
<b>System Date</b>	Set this to the current date
<b>Pumping Mode</b>	Empty (Pump Down application) or Fill (Pump Up application)
<b>Lead Select<sup>1</sup></b>	P1, P2, P3 (if 3 pumps selected), or Auto
<b>Access Password<sup>2</sup></b>	0= No password, 1-9999 password set

Press the yellow button for each mode to cycle through options.

**Notes:**

<sup>1</sup> The **Lead Select** button will only work if at least one of the HAND/OFF/AUTO selector switches in the control panel is set to the AUTO position. If **P1** is selected, it will start as the lead pump every time the lead pump is called to run. If the **Lead Select** is set to **Auto** (default), the lead pump will alternate every time the lead pump is called to run.

<sup>2</sup> Setting the password with a value from 1 to 9999 will prevent future access to the **Setup** menu. A password entry screen will be prompted prior to entering the **Setup** menu.

If the optional Ethernet card is installed then the **Ethernet Setup** button appears. This allows the user to adjust the IP Address information for the LevelView to be accessible via their SCADA system utilizing Modbus TCP/IP.

Ethernet Setup

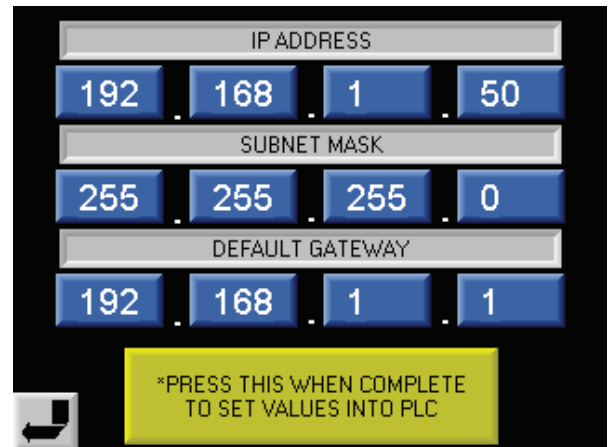

The **Reset** button opens a screen with options to reset individual counters and hour meters.

Reset

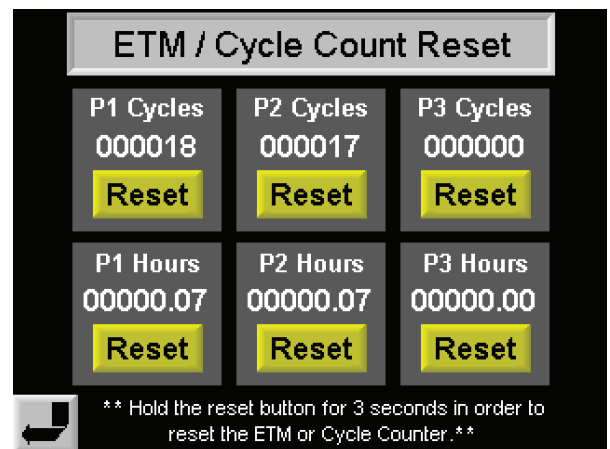

Pressing the **I/O Status & Prog. Outputs** button opens the **INPUT/OUTPUT STATUS** screen. This screen enables the user to monitor the status of all Inputs and Outputs of the controller. This is a very useful tool when troubleshooting.

I/O Status & Prog. Outputs

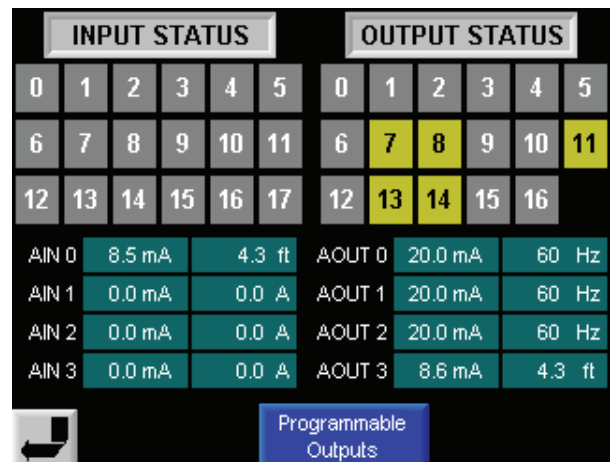

PROGRAMMABLE  
OUTPUTS

Pressing the **PROGRAMMABLE OUTPUTS** button opens the **Programmable Output Relays** screen. This screen enables the user to configure the operation of the relay outputs. Seven output relays are available and can be user programmed to activate based on the following conditions:

1. Pump 1 Running
2. Pump 2 Running
3. Pump 3 Running
4. Transducer Low Level
5. Transducer High Level
6. Float Low Level
7. Float High Level
8. Pump 1 Failure
9. Pump 2 Failure
10. Pump 3 Failure
11. Pump 1 Seal Failure
12. Pump 2 Seal Failure
13. Pump 3 Seal Failure
14. Backup Float Mode Active
15. Power/Phase Failure
16. Transducer Open Alarm
17. General Alarm
18. Pump 1 Reverse Call
19. Pump 2 Reverse Call
20. Pump 3 Reverse Call
21. Tank Cleanout Active

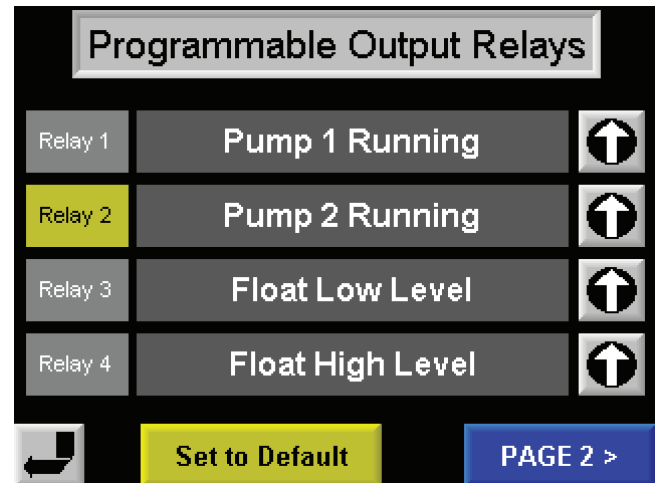

## PUMP DATA SCREEN

The **Pump Data** screen is for information only. It is a record of the pump HP, Volts, and FLA. This data can be viewed remotely when connected to the PRIMEX® PUMP WATCH® cellular monitoring system.

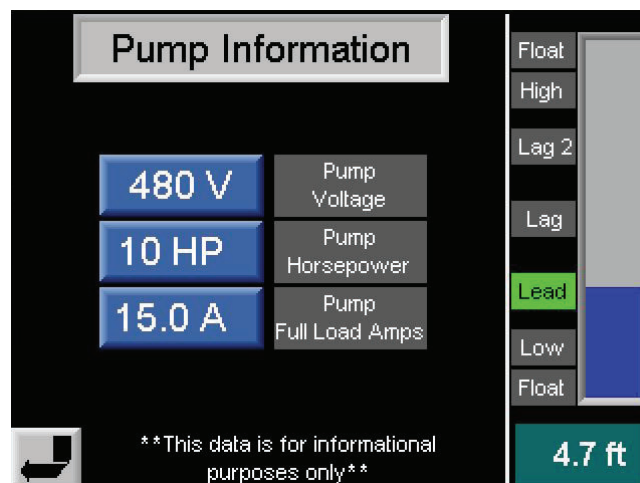

## LEVEL VIEW™ POWER UP SCREEN (VERSION)

On power up, the screen will display the version of the program. Always have the version number ready when contacting the factory for service.

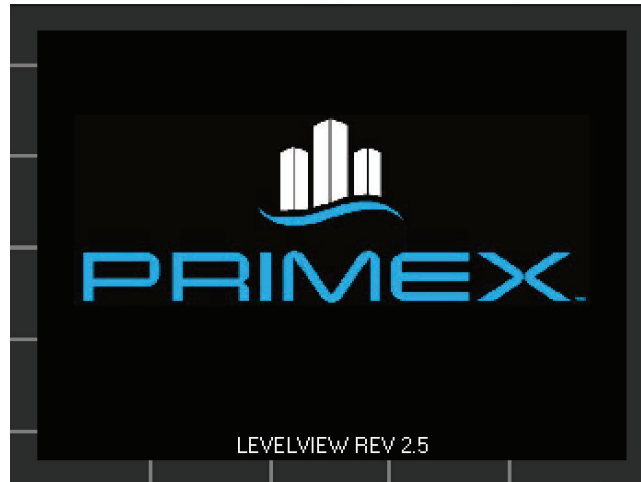

## I/O TERMINAL CONFIGURATION

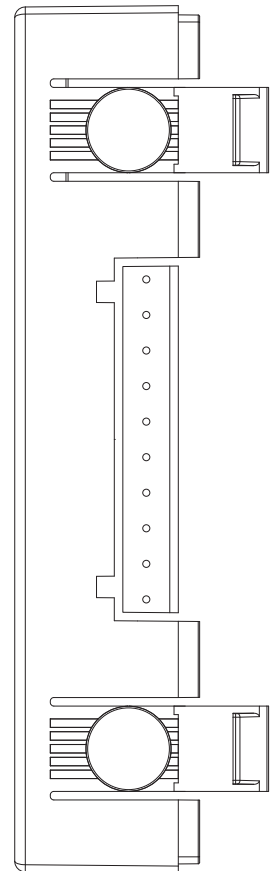
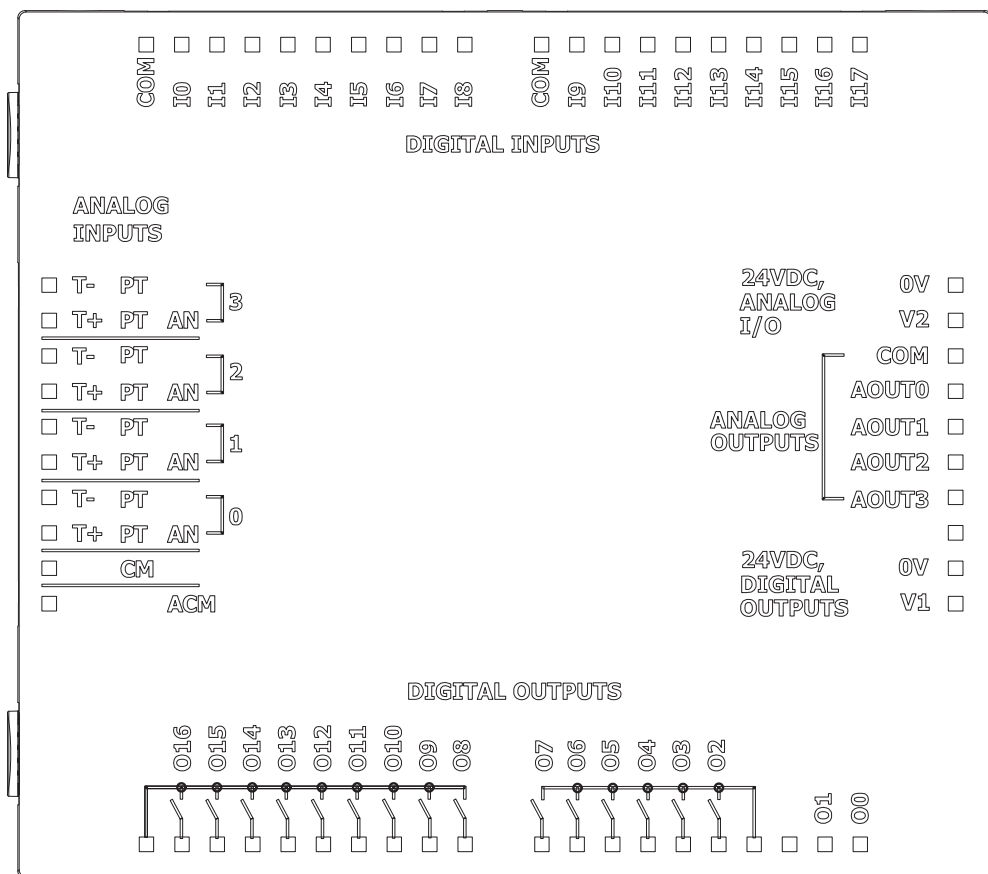

# LEVEL VIEW™ I/O TABLE

DIGITAL INPUT TERMINALS		
INPUT	TYPE	DESCRIPTION
COM	0~8	INPUT COMMON (0~8)
I0	DIGITAL PNP	PUMP 1 RUNNING
I1	DIGITAL PNP	PUMP 2 RUNNING
I2	DIGITAL PNP	PUMP 3 RUNNING
I3	DIGITAL PNP	PUMP 1 FAULT*
I4	DIGITAL PNP	PUMP 2 FAULT*
I5	DIGITAL PNP	PUMP 3 FAULT*
I6	DIGITAL PNP	PUMP 1 AUTO
I7	DIGITAL PNP	PUMP 2 AUTO
I8	DIGITAL PNP	PUMP 3 AUTO
COM	9~17	INPUT COMMON (9~17)
I9	DIGITAL PNP	PUMP 1 SEAL FAIL
I10	DIGITAL PNP	PUMP 2 SEAL FAIL
I11	DIGITAL PNP	PUMP 3 SEAL FAIL
I12	DIGITAL PNP	LOW LEVEL FLOAT
I13	DIGITAL PNP	HIGH LEVEL FLOAT
I14	DIGITAL PNP	BACK UP FLOATS ACTIVE
I15	DIGITAL PNP	POWER/PHASE FAULT*
I16	DIGITAL PNP	ILLEGAL ENTRY
I17	DIGITAL PNP	GENERATOR FAULT

24 VDC PNP inputs  
\*Normally closed, opens on fault

ANALOG INPUT TERMINALS			
	INPUT	TYPE	DESCRIPTION
	ACM	4-20mA Common	ANALOG COMMON
	CM	NA	NO CONNECTION
0	T+PT AN	4-20mA INPUT 0	LEVEL
	T-PT	NC	
1	T+PT AN	4-20mA INPUT 1	PUMP 1 AMPS
	T-PT	NC	
2	T+PT AN	4-20mA INPUT 2	PUMP 2 AMPS
	T-PT	NC	
3	T+PT AN	4-20mA INPUT 3	PUMP 3 AMPS
	T-PT	NC	

Resolution at 4-20mA 3277 to 16384 (13107 units).

24 VDC OUTPUT TERMINALS		
INPUT	TYPE	DESCRIPTION
0V	DIGITAL OUTPUT POWER	0V
V1	DIGITAL OUTPUT POWER	24 VDC

DIGITAL OUTPUT TERMINALS		
INPUT	TYPE	DESCRIPTION
COM	NA	NO CONNECTION
O0	NA	NO CONNECTION
O1	NA	NO CONNECTION
COM	2~7	COMMON FOR OUTPUTS 2~7
O2	RELAY OUTPUT 2	CALL PUMP 1 (AUTO)
O3	RELAY OUTPUT 3	CALL PUMP 2 (AUTO)
O4	RELAY OUTPUT 4	CALL PUMP 3 (AUTO)
O5	RELAY OUTPUT 5	HIGH LEVEL TRANSDUCER
O6	RELAY OUTPUT 6	LOW LEVEL TRANSDUCER
O7	RELAY OUTPUT 7	GENERAL ALARM
O8	RELAY OUTPUT 8	GENERAL ALARM
O9	RELAY OUTPUT 9	PROGRAMMABLE RELAY 1
O10	RELAY OUTPUT 10	PROGRAMMABLE RELAY 2
O11	RELAY OUTPUT 11	PROGRAMMABLE RELAY 3
O12	RELAY OUTPUT 12	PROGRAMMABLE RELAY 4
O13	RELAY OUTPUT 13	PROGRAMMABLE RELAY 5
O14	RELAY OUTPUT 14	PROGRAMMABLE RELAY 6
O15	RELAY OUTPUT 15	PROGRAMMABLE RELAY 7
O16	N/A	NO CONNECTION
COM	8~16	

Output current 3A maximum per output (resistive load)  
8A maximum total for common (resistive load)  
Rated voltage 250 VAC / 30 VDC  
Output 12 (Prog. Relay 4): Defaults to Tank Cleanout Active if Tank Cleanout is Enabled  
Output 13 (Prog. Relay 5): Defaults to "Pump 1 Reverse Call" if Jam Monitoring is enabled for Pump 1  
Output 14 (Prog. Relay 6): Defaults to "Pump 2 Reverse Call" if Jam Monitoring is enabled for Pump 2  
Output 15 (Prog. Relay 7): Defaults to "Pump 3 Reverse Call" if Jam Monitoring is enabled for Pump 3.

ANALOG OUTPUT TERMINALS		
INPUT	TYPE	DESCRIPTION
0V	ANALOG I/O POWER	0V
V2	ANALOG I/O POWER	24 VDC
COM	COMMON	ANALOG OUTPUT COMMON
AOUT0	4-20mA OUTPUT 0	PUMP 1 COMMAND SPEED
AOUT1	4-20mA OUTPUT 1	PUMP 2 COMMAND SPEED
AOUT2	4-20mA OUTPUT 2	PUMP 3 COMMAND SPEED
AOUT3	4-20mA OUTPUT 3	ADJ. LEVEL RETRANSMIT

Resolution 12 bit (4096 units)

POWER		
INPUT	TYPE	DESCRIPTION
+V	I/O MODULE POWER	24 VDC
0V	I/O MODULE POWER	0V
GND	I/O MODULE POWER	GROUND

Operating voltage 20.4 to 28.8 VDC  
Maximum current consumption: 400mA@24VDC

# ELECTRICAL WIRING DIAGRAM

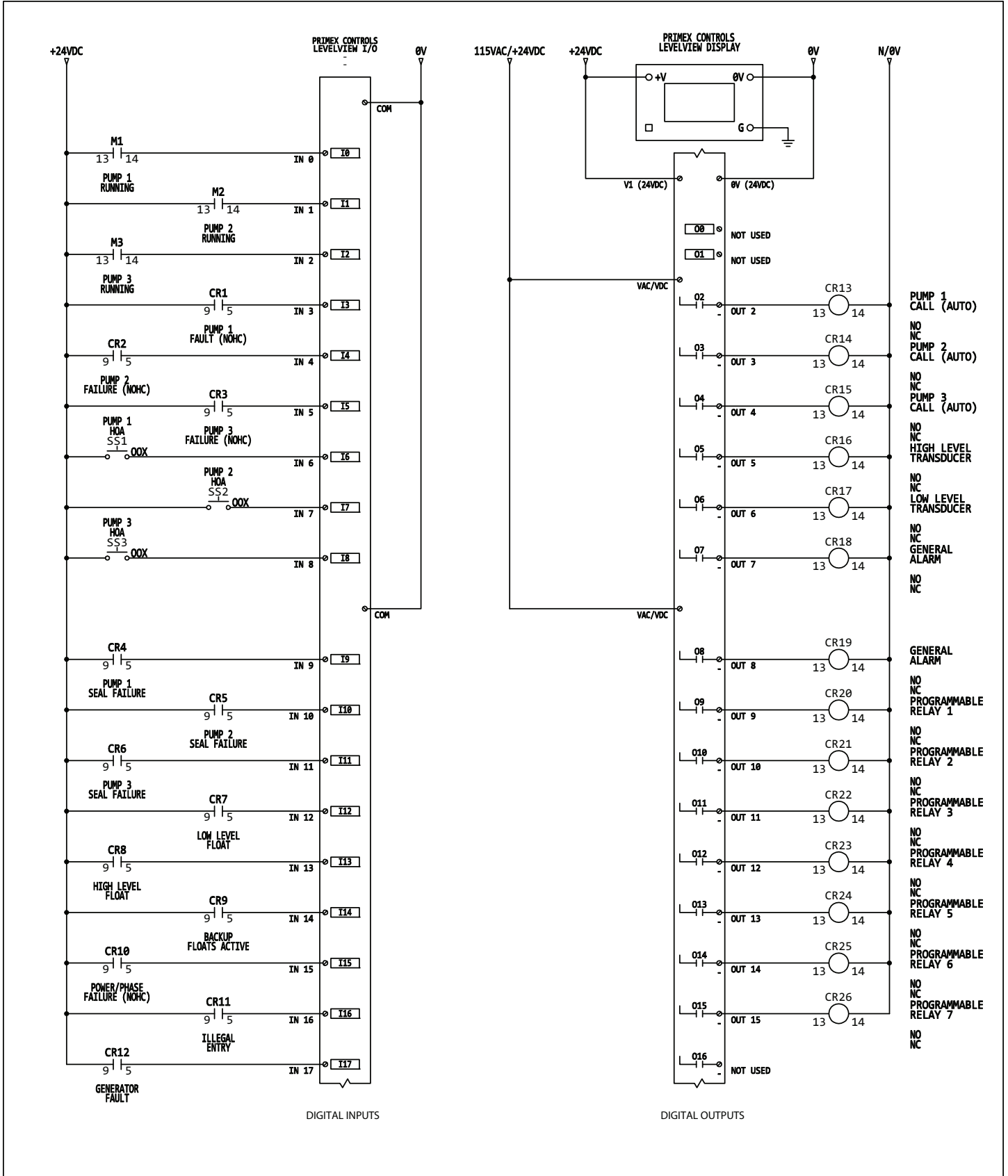

# ELECTRICAL WIRING DIAGRAM

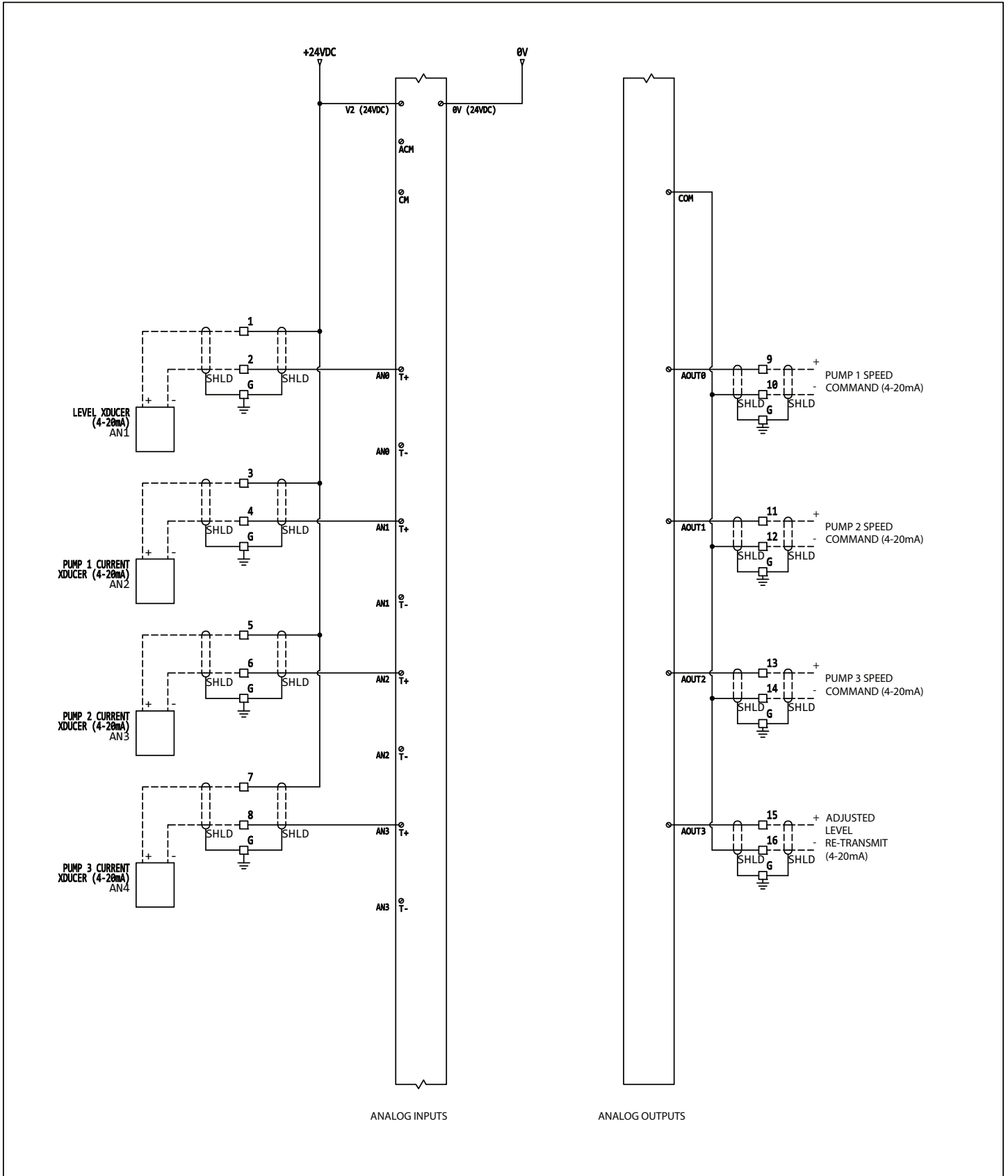

# DIMENSIONS AND MOUNTING

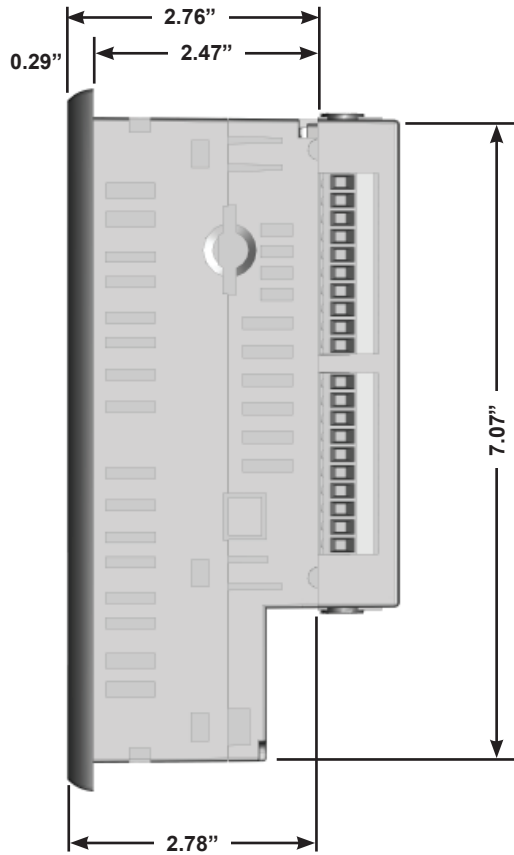
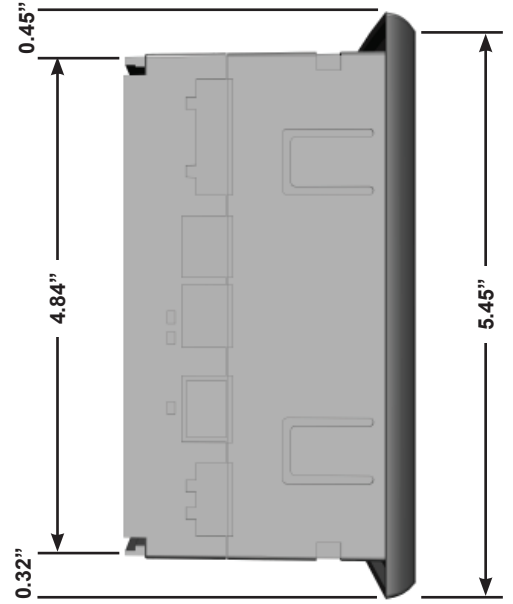
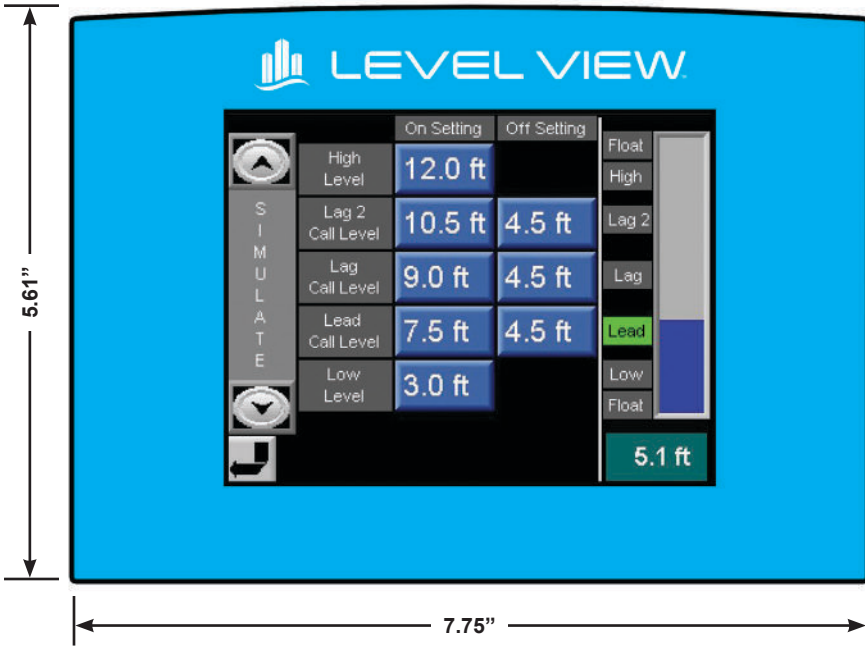

## DIP SWITCH SETTINGS

### RS485 to RS232: Changing DIP Switch Settings

The ports are set to RS485 by factory default.

To change the settings, first remove the Snap-in I/O Module, if one is installed, and then set the switches according to the following table.

### RS232/RS485: Factory Default Dip Switch Settings

The settings below are for each COM port.

	SWITCH SETTINGS					
	1	2	3	4	5	6
<b>RS485</b>	OFF	OFF	OFF	ON	OFF	ON
<b>RS485 with termination**</b>	ON	ON	OFF	ON	OFF	ON
<b>**Causes the unit to function as an end unit in an RS485 network.</b>						

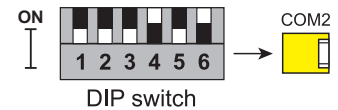
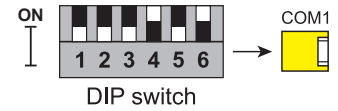

## I/O MODULE JUMPERS

I/O Module jumper settings are programmed at the factory.

### Analog Input jumper settings - Bottom of PCB Board

Set to 4-20mA Input

JUMPER	FUNCTION	POSITION	
		DEFAULT (UNI)	LEVEL VIEW™
3	ANALOG INPUT 0	A	A
4		A	B
5		A	B
6	ANALOG INPUT 1	A	A
7		A	B
8		A	B
9	ANALOG INPUT 2	A	A
10		A	B
11		A	B
12	ANALOG INPUT 3	A	A
13		A	B
14		A	B

### Analog Output jumper settings - Top of PCB Board

Set to 4-20mA Output

JUMPER	FUNCTION	POSITION	
		DEFAULT (UNI)	LEVEL VIEW™
1	ANALOG OUTPUT 0	B	A
2	ANALOG OUTPUT 1	B	A
3	ANALOG OUTPUT 2	B	A
4	ANALOG OUTPUT 3	B	A

# LEVEL VIEW™ CONTROLLER SETPOINTS LIST

STATION NAME:				
START UP DATE:				
CONTROLLER REV:				
LEVEL SETUP	MIN	MAX	FACTORY SETTING	USER
High Level ON	OFFSET	RANGE		
Lag 2 Call Level ON	OFFSET	RANGE		
Lag 2 Call Level OFF	OFFSET	RANGE		
Lag Call Level ON	OFFSET	RANGE		
Lag Call Level OFF	OFFSET	RANGE		
Lead Call Level ON	OFFSET	RANGE		
Lead Call Level OFF	OFFSET	RANGE		
Low Level ON	OFFSET	RANGE		
<b>Tank Cleanout</b>				
Tank Cleanout	Disabled	Enabled		
Cycle or Timer Based	Cycle	Timer		
Cycle(s) / Time Between Cleanout	1 / 00:00:00	99999 / 59:59:59		
Runtime Past Lead Off Level	00:00	59:59		
<b>Cleanout Current Monitoring</b>				
Cleanout Current Monitoring	Disabled	Enabled		
P1 Cleanout Amps	0.0	P1 Amps Xducer Range		
P1 Cleanout Amps Time	00:00	59:59		
P2 Cleanout Amps	0.0	P2 Amps Xducer Range		
P2 Cleanout Amps Time	00:00	59:59		
P3 Cleanout Amps	0.0	P3 Amps Xducer Range		
P3 Cleanout Amps Time	00:00	59:59		
<b>VFD CONTROL SETUP</b>				
Frequency at Lag 2 Level	30	60		
Start Frequency at Lag Level	30	60		
Start Frequency at Start Level	30	60		
Hold Time at 60Hz on Ramp Up (sec)	0	59		
<b>SENSOR SETUP</b>				
Level Transducer Range	0.0	999.9		
Level Transducer Offset	0.0	999.9		
<b>TIMER SETUP</b>				
High Level Alarm Off/On Delay (mm:ss)	00:00	59:59		
Low Level Alarm On/Off Delay (mm:ss)	00:00	59:59		
Lag Pump 1 - Start Delay (mm:ss)	00:00	59:59		
Lag Pump 2 - Start Delay (mm:ss)	00:00	59:59		
Max Run Timer (hh:mm)	00:00	59:59		
<b>FLOW CALCULATION SETUP</b>				
Cylindrical / Rectangular / Disabled	*Various*	*Various*		
<b>Cylindrical</b>				
Tank Diameter	0.5	99.9		
<b>Rectangular</b>				
Length	0.5	99.9		
Width	0.5	99.9		
<b>AMPS SETUP</b>				
Current Monitoring	Disabled	Enabled		
Pump 1 Amps Xducer Range	0.0	999.9		
Pump 2 Amps Xducer Range	0.0	999.9		
Pump 3 Amps Xducer Range	0.0	999.9		
High Current Delay (mm:ss)	00:00	59:59		
P1 High Current	0.0	999.9		
P2 High Current	0.0	999.9		
P3 High Current	0.0	999.9		
<b>Jam Detection Setup - Pump 1</b>				
Jam Monitoring	Disabled	Enabled		
Pump Full Load Amps	0.0	P1 Amps Xducer Range		
Normal Trip %	100	Calculated % = P1 Range		
Normal Trip Delay (mm:ss)	00:00	59:59		
Rapid Trip %	100	Calculated % = P1 Range		
Jam Clear Time (mm:ss)	00:00	59:59		
Jams Before Fault	1	99		
Initial Rev. time (mm:ss)	00:00	59:59		
Coast Rev to Fwd (mm:ss)	00:00	59:59		
Coast Fwd time (mm:ss)	00:00	59:59		
<b>Jam Detection Setup - Pump 2</b>				
Jam Monitoring	Disabled	Enabled		
Pump Full Load Amps	0.0	P2 Amps Xducer Range		
Normal Trip %	100	Calculated % = P2 Range		
Normal Trip Delay (mm:ss)	00:00	59:59		
Rapid Trip %	100	Calculated % = P2 Range		
Jam Clear Time (mm:ss)	00:00	59:59		
Jams Before Fault	1	99		
Initial Rev. time (mm:ss)	00:00	59:59		
Coast Rev to Fwd (mm:ss)	00:00	59:59		
Coast Fwd time (mm:ss)	00:00	59:59		

# LEVEL VIEW™ CONTROLLER SETPOINTS LIST

AMPS SETUP (continued)	MIN	MAX	FACTORY SETTING	USER
<b>Jam Detection Setup - Pump 3</b>				
Jam Monitoring	Disabled	Enabled		
Pump Full Load Amps	0.0	P3 Amps Xducer Range		
Normal Trip %	100	Calculated % = P3 Range		
Normal Trip Delay (mm:ss)	00:00	59:59		
Rapid Trip %	100	Calculated % = P3 Range		
Jam Clear Time (mm:ss)	00:00	59:59		
Jams Before Fault	1	99		
Initial Rev. time (mm:ss)	00:00	59:59		
Coast Rev to Fwd (mm:ss)	00:00	59:59		
Coast Fwd time (mm:ss)	00:00	59:59		
<b>Dry Run Protection Setup</b>				
Dry Run Protection	Disabled	Enabled		
Dry Run Timer (mm:ss)	00:00	59:59		
P1 Dry Run Amps	0.0	P1 Amps Xducer Range		
P2 Dry Run Amps	0.0	P2 Amps Xducer Range		
P3 Dry Run Amps	0.0	P3 Amps Xducer Range		
<b>SYSTEM SETUP</b>				
# of Pumps	Duplex	Triplex		
VFD Mode	Disabled	Enabled		
System Time	00:00:00	23:59:59		
System Date	01/01/00	12/31/99		
Pumping Mode	Empty	Fill		
Lead Select	P1, P2, P3, Auto	P1, P2, P3, Auto		
Access Password	0	9999		
<b>Ethernet Setup (If Installed)</b>				
IP Address	0.0.0.0	255.255.255.255		
Subnet Mask	0.0.0.0	255.255.255.255		
Gateway	0.0.0.0	255.255.255.255		
<b>Pump Information</b>				
Pump Voltage	0	999		
Pump Horsepower	0	999		
Pump Full Load Amps	0.0	999.9		
<b>Programmable Outputs</b>				
Relay 1	*Various*	*Various*		
Relay 2	*Various*	*Various*		
Relay 3	*Various*	*Various*		
Relay 4	*Various*	*Various*		
Relay 5	*Various*	*Various*		
Relay 6	*Various*	*Various*		
Relay 7	*Various*	*Various*		



+1-844-4PRIMEX (477-4639)  
WWW.PRIMEXCONTROLS.COM

PN 1043154B 10/24  
© 2013 SJE, Inc. All Rights Reserved.  
PRIMEX is a trademark of SJE, Inc.