

PUMP WATCH™ EXPRESS

WEB-BASED CELLULAR MONITORING

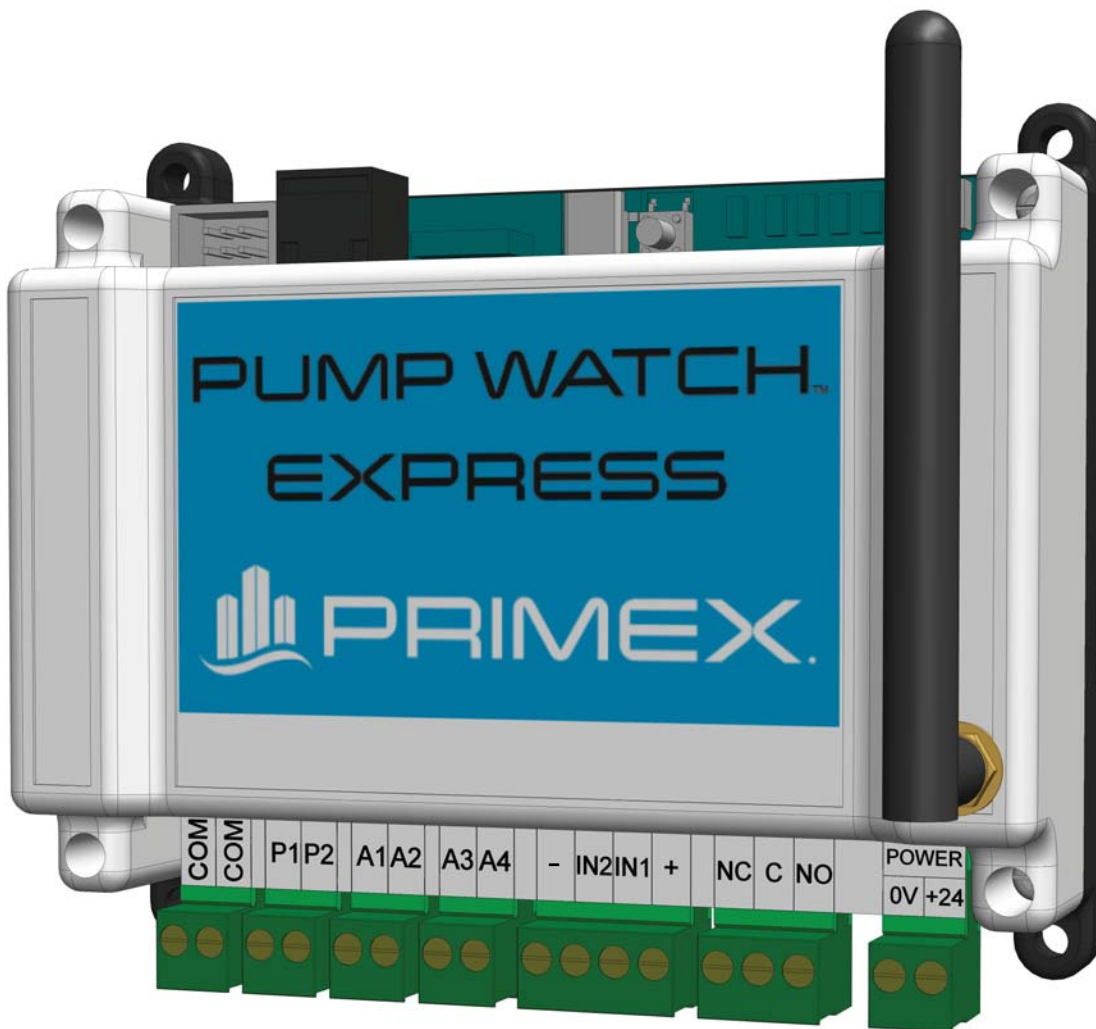

User Manual



844-4PRIMEX (477-4639)
WWW.PRIMEXCONTROLS.COM

WARNINGS

Failure to read and understand the information provided in this manual may result in personal injury or death, damage to the product or product failure. Please read each section in its entirety and be sure you understand the information provided in the section and related sections before attempting any of the procedures or operations given.



| | |
|---|---|
| <p>Failure to follow these precautions could result in serious injury or death. Keep these instructions with warranty after installation. This product must be installed in accordance with National Electrical Code, ANSI/NFPA 70 so as to prevent moisture from entering or accumulating within the controller housing.</p> | |
| <p>⚠ WARNING</p>  | <p>ELECTRICAL SHOCK HAZARD</p> <p>A qualified service person must install and service this product according to applicable codes and electrical schematics. Disconnect power prior to servicing an equipment with the Pump Watch™ Express.</p> |
| <ul style="list-style-type: none">• Do not connect power to this equipment if it has been damaged or has any missing parts.• Do not install in areas with: excessive or conductive dust, corrosive or flammable gas, moisture or rain, excessive heat, regular impact shocks, or excessive vibration. | |
| <p>⚠ WARNING</p>  | <p>EXPLOSION OR FIRE HAZARD</p> <p>Do not use this product with flammable liquids. Do not install in hazardous locations as defined by National Electrical Code, ANSI/NFPA 70.</p> |

TABLE OF CONTENTS

| | |
|--|----|
| Introduction & Pump Watch™ Express Introduction Ordering Information.. | 1 |
| Ordering Information..... | 2 |
| Activation and Service | 3 |
| Pump Watch™ Express Setup Form..... | 4 |
| Receiving and Inspection..... | 5 |
| Pump Watch™ Express RTU Features | 6 |
| Mounting the Pump Watch™ Express RTU..... | 7 |
| Wiring..... | 9 |
| Pump Watch™ Gateway Schematic - View Controller | 10 |
| Pump Watch™ Gateway Schematic - PC-3000X Controller | 12 |
| Sensor Wiring | 12 |
| Mounting the Pump Watch™ Express Panel & Dimensions | 13 |
| Wiring Methods..... | 14 |
| System View | 15 |
| Wiring..... | 16 |
| Pump Watch™ Express Troubleshooting | 17 |
| Logging In..... | 18 |
| Access Levels..... | 19 |
| Viewing/Searching for RTUs..... | 20 |
| Placing an RTU on the Map | 22 |
| User Setup..... | 23 |
| Dashboard | 24 |
| RTU Setup | 25 |
| Online/Offline Trigger Alert Setup..... | 26 |
| RTU Visualization | 27 |
| Main Screen Configuration | 29 |
| RTU Parameter Configuration | 30 |
| Station Parameter Configuration | 31 |
| Alarm Notification Setup | 33 |
| Connecting Alerts to Users..... | 34 |
| Reports & Trending..... | 38 |
| Customer Service Agreement and Terms of Use..... | |

INTRODUCTION

Designed for municipal wastewater lift stations and similar applications, the Pump Watch™ Express is a simple and effective RTU for management of a wastewater collection system via a cellular network. Alarms are monitored and service personnel notified in the event of a failure.

Data logging and trending of critical information enables the User to visually track system performance and recognize impending problems. The station data can be visualized in a simple and intuitive way from your web browser on a PC, tablet or smart phone.

The Pump Watch™ Express remote monitoring system is designed to be connected to most simplex or duplex lift station type control panels. The Pump Watch™ Express RTU monitors pump run, run time, cycles, amps*, and flow. It can also monitor system in-flow*, power failure, level and level alarms*. All of this data is then relayed to the cloud, via a cellular network, to a secure website, and can be accessed and monitored from virtually anywhere in the world.

The Pump Watch™ Gateway uses the RS-485 port to communicate with the following controllers:

Level View
Station View
Energy View
PC-3000C

The protocol used is Modbus RTU.

* Amps, flow, and level measurements require Pump Watch™ Express Premium or Gateway services.

ORDERING INFORMATION

Three versions are available:

- **Pump Watch™ Express Light** (Digital I/O only)
- **Pump Watch™ Express Premium** (Analog & Digital I/O)
- **Pump Watch™ Express Gateway** (RS-485 - Modbus Communication)

The RTU module can be supplied for direct panel mounting, or pre-assembled in NEMA 4X enclosure for outdoor mounting near an existing panel.

Note: Pump Watch™ Express units include 1 year of cellular service, small antenna, & user manual.
Pump Watch™ includes 2 years of cellular service, small antenna, a& user manual.

1. Pump Watch™ Express RTU

For installation inside a control panel.

Parts Included:



Pump Watch™ Express Light

or



Pump Watch™ Express Premium

or



Pump Watch™ Express Gateway

+



3.7V Lithium Battery

+



100/150/200A Current Transducer (Premium version only)

2. Pump Watch™ Express NEMA 4X Panel

For installation outside a control panel or for retrofit applications

Includes:

- 10X8X6 NEMA 4X thermoplastic enclosure
- Pump Watch™ Express
- DC Power supply and battery backup (Digital I/O only)
- Requires 120/240 VAC supply power
- I/O terminals for hard wiring with existing control panel
- 100/150/200A to 4-20mA current transducer (Premium version only)
- Can monitor lift stations with up to 2 pumps



Pump Watch™ Express

3. Options

- High Gain Antenna (pole mounted)
- Low Loss Cable - 20ft, 40ft and 60ft
- 3dB Antenna with 6 foot cable
- Mounting Bracket (3dB Antenna) for side mounting.
- 24 Vdc Battery Backup (Analog & Digital)
- PSLT, 4-20mA submersible level transmitter



1038516



1038517



1038518



1038520

ACTIVATION AND SERVICE

The data management for Pump Watch™ remote cellular devices is hosted by: **Aqua Management Incorporated**, 6280 S. Valley View Blvd. Suite 212, Las Vegas, NV 89118

All Pump Watch™ Express RTUs are provided with a year of pre-paid cellular service. Activation of your device is required for operation. An account needs to be setup if this is your first Pump Watch™ device.

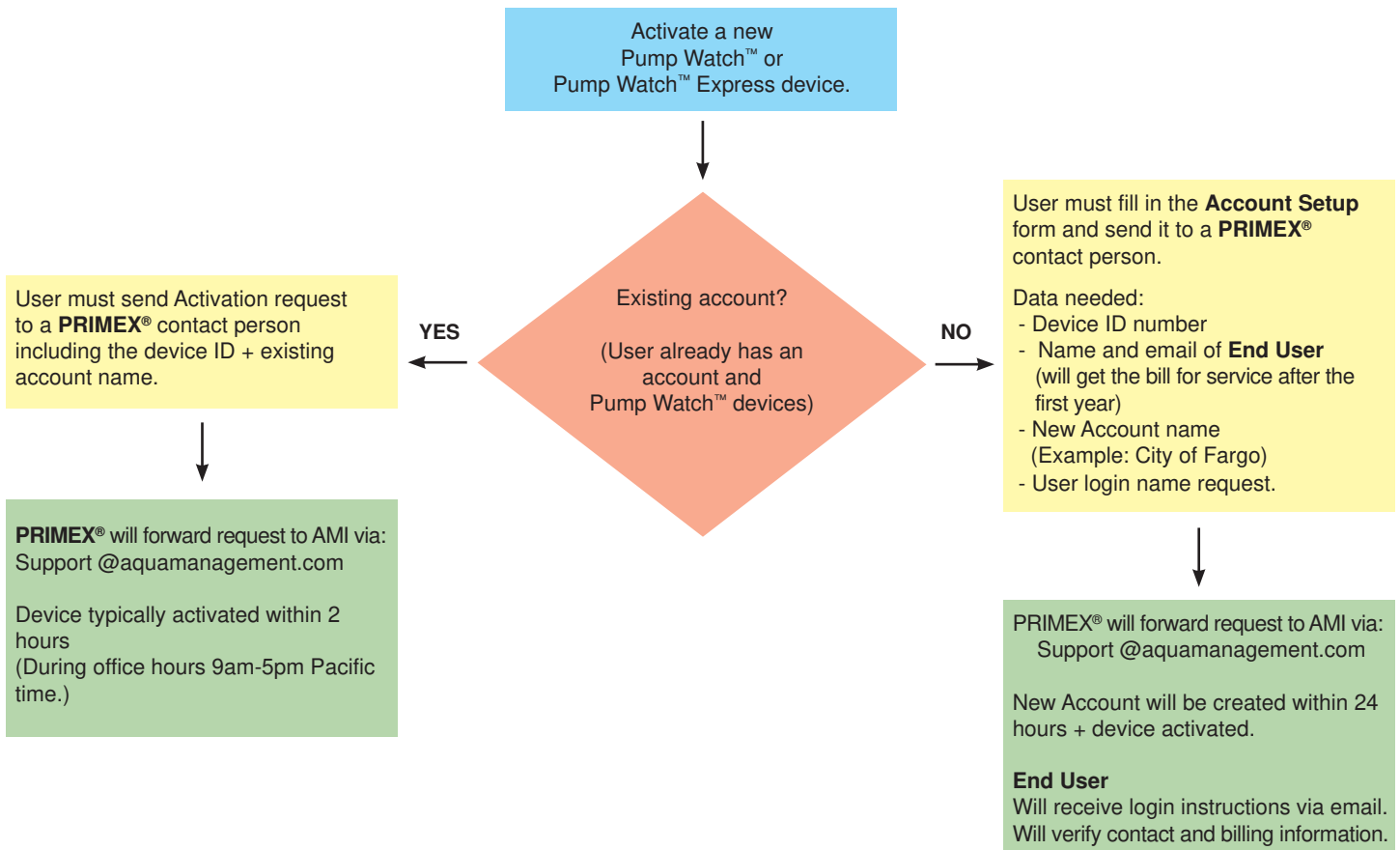

Pump Watch™ Express ID number (Located on the device)

LIGHT:

ID: 60XXXLIGHT - 3G GSM

ID: 65XXXLIGHT - CDMA

ID: 64XXXLIGHT - LTE

PREMIUM:

ID: 63XXXPREMIUM - 3G GSM

ID: 68XXXPREMIUM - CDMA

ID: 69XXXPREMIUM - LTE

GATEWAY:

ID: 66XXXGATEWAY - 3G GSM

ID: 62XXXGATEWAY - CDMA

ID: 67XXXGATEWAY - LTE

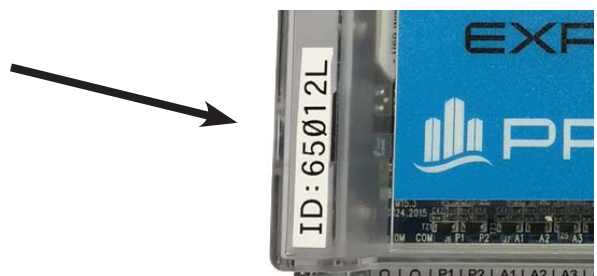

The Account Setup Form (on the next page) can be downloaded from:
www.primexcontrols.com/pumpwatchremotemonitoring.html

Pump Watch (Express) Account Setup and Activation Form

Please fill in for **New** or **Existing** accounts. If existing account, provide device ID, account name and

| | | |
|---------------------------------|--|------------------------------------|
| Pump Watch Unit ID: | | Example: 68023 |
| Account Name: | | Example: City of Fargo |
| User First Last Name: | | Example: John Smith |
| User Login Name: | | Example: jsmith |
| User Mobile Number: | | Example: 555-222-7777 |
| User Email: | | Example: jsmith@cfargo.gov |
| Billing Address: | | Example: 1234 Elm St |
| Billing City, State Zip: | | Example: Fargo, MN 58102 |
| Billing First Last Name: | | Example: Judy Miller |
| Billing Phone: | | Example: 555-222-8888 |
| Billing Email: | | Example: jmiller@cfargo.gov |

Who should use this form?

End Users who wish to create an account for monitoring Pump Watch devices and those who will be responsible for the service fee after the initial period is complete.

Example of End Users: A City, Municipality, Water district, Utility Service Company, etc...

Why create an account?

This form provides contact and billing information to AMI (Service Company). This will allow them to contact the End User directly with service renewal options after the initial period is complete.

Information from this new account will be used to setup a login username and password to grant access to the web portal.

Where to send this form?

Complete this form and send to your PRIMEX contact person:

| | | |
|-------------------|---|--|
| Clearwater, FL | Julian Atchia (800-746-6287 x3462) | julian.atchia@sjerhombus.com |
| Clearwater, FL | Russell Gardner (800-746-6287 x5110) | russell.gardner@primexcontrols.com |
| Ashland, OH | Jason Mailloux (800-746-6287 x4110) | jason.mailloux@primexcontrols.com |
| Plymouth, MN | Troy LaDoux (763-559-0568 x6915) | troy.ladoux@sjerhombus.com |
| Detroit Lakes, MN | Marty Grabarkewitz (800-746-6287 x3357) | marty.grabarkewitz@primexcontrols.com |

When to create a new account?

It is recommended this form be submitted at least 24 hours prior to the device activation.

What happens next?

Once the form is submitted, the User will receive an e-mail from AMI with a link and instructions for login and account verification. Click on the link or cut and paste it into your browser URL. Once the account is verified, power up the device for final activation and setup. The device is then ready for use.

For activation of future Pump Watch RTUs

Once the account is setup, the End User can activate additional Pump Watch RTUs in the future by filling in the **Account Name** and the **Device ID** of the Pump Watch that needs to be activated.

RECEIVING AND INSPECTION

Pump Watch™ Express Light

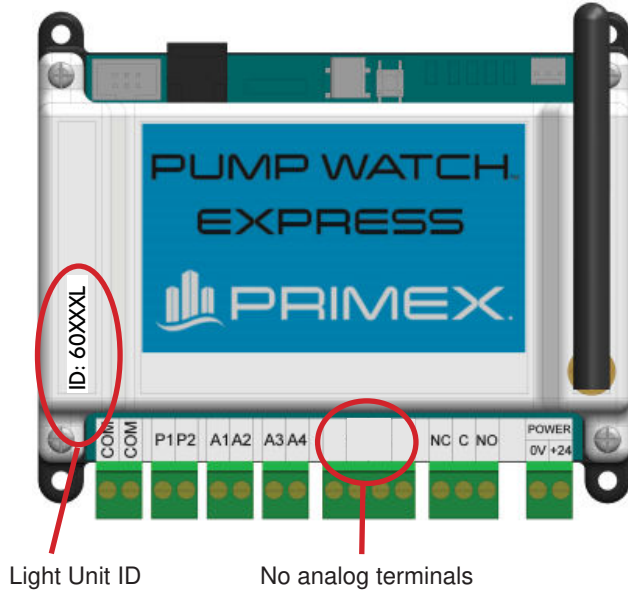

Pump Watch™ Express Premium

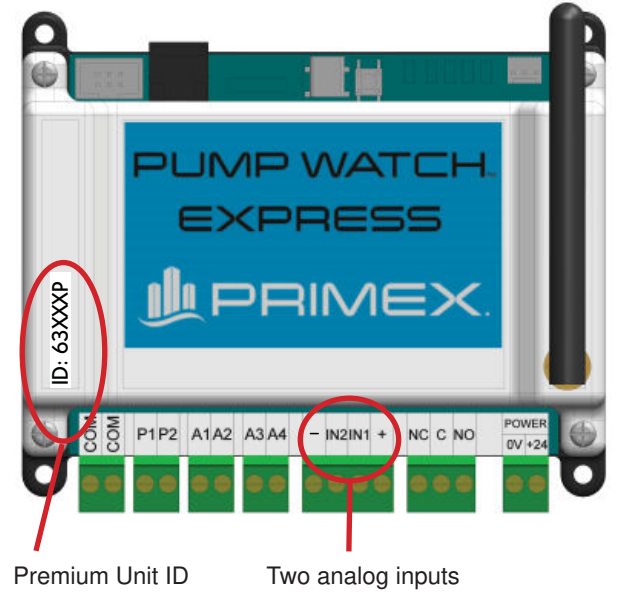

Pump Watch™ Express Gateway

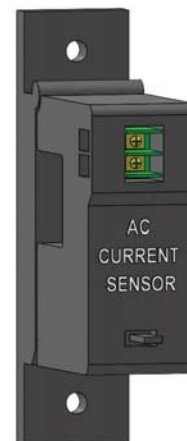
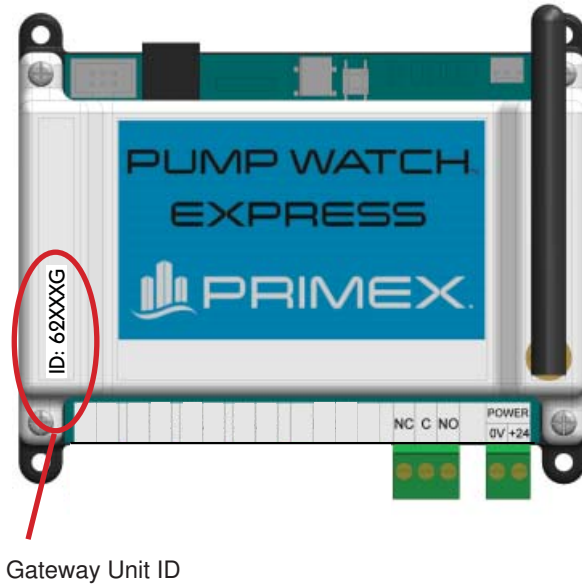

(Premium version only)

PUMP WATCH™ EXPRESS FEATURES

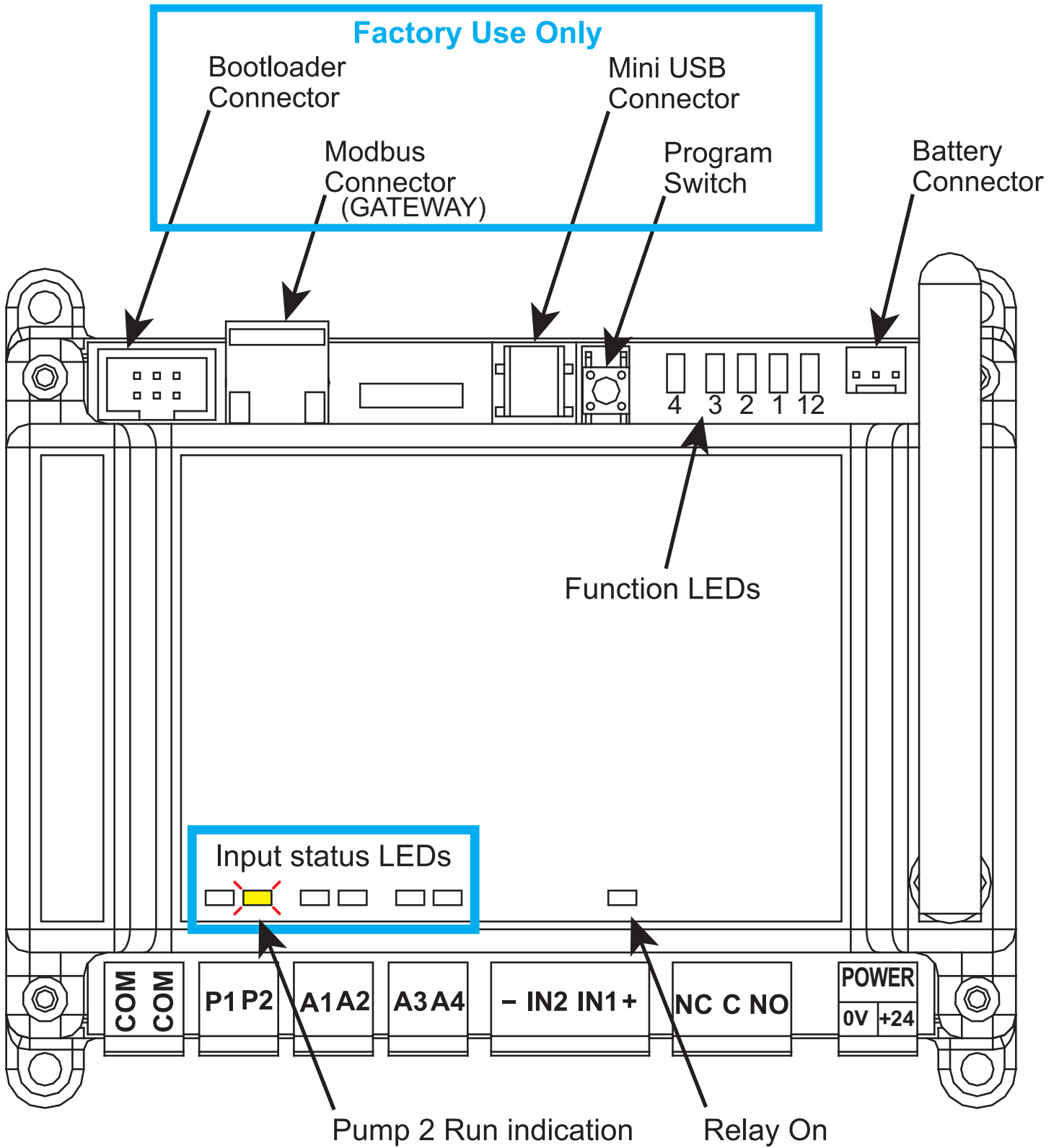

MOUNTING THE PUMP WATCH™ EXPRESS RTU

5.5"W x 4.5"H x 3.5"D (with antenna at 90 degrees as shown)
Can be din rail mounted or panel mounted with 4 screws.

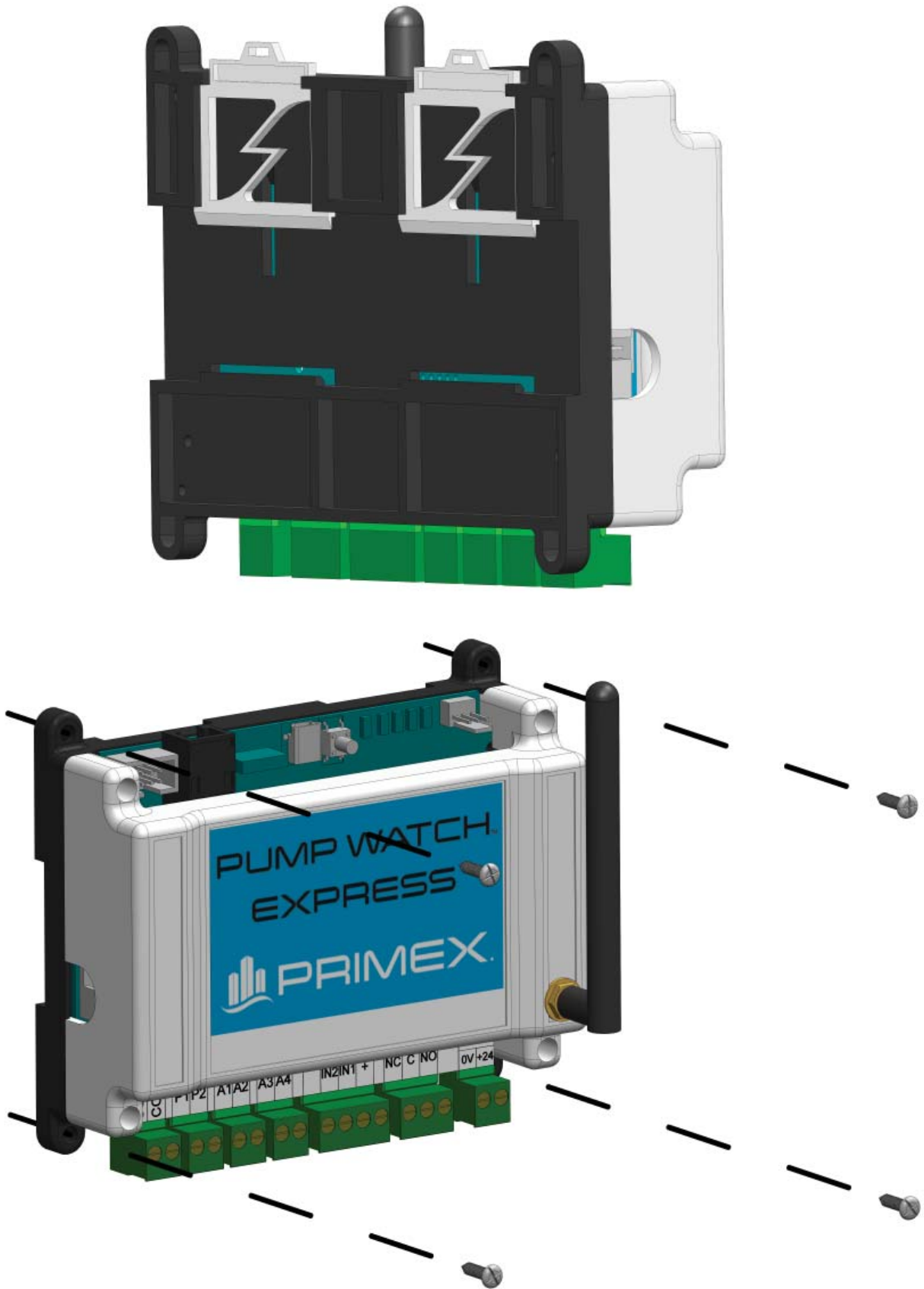

MOUNTING THE PUMP WATCH™ EXPRESS RTU

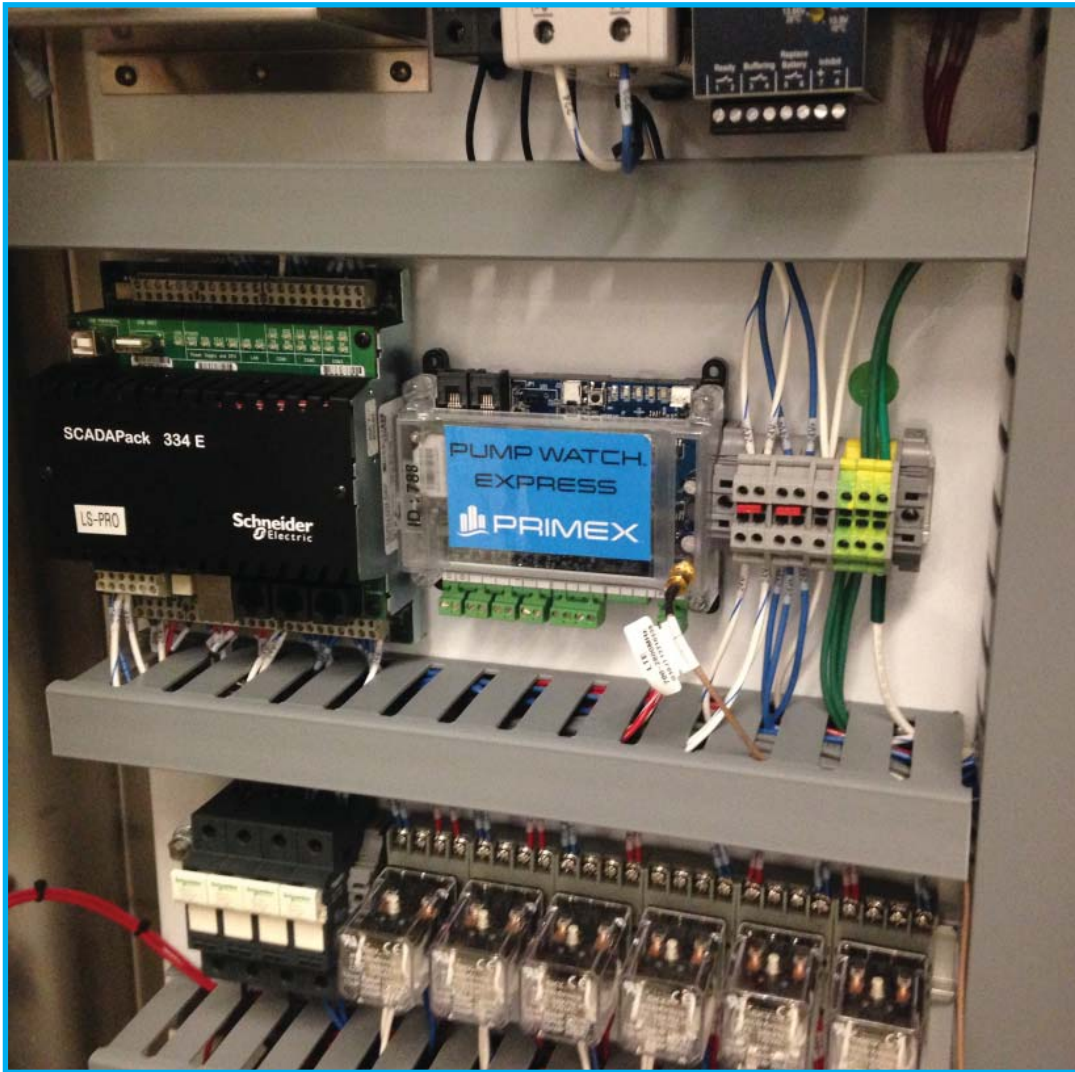

Backup Battery Connection



Optional Outdoor Antenna and Mounting Bracket

WIRING

PUMP WATCH™ EXPRESS PREMIUM RTU SCHEMATIC

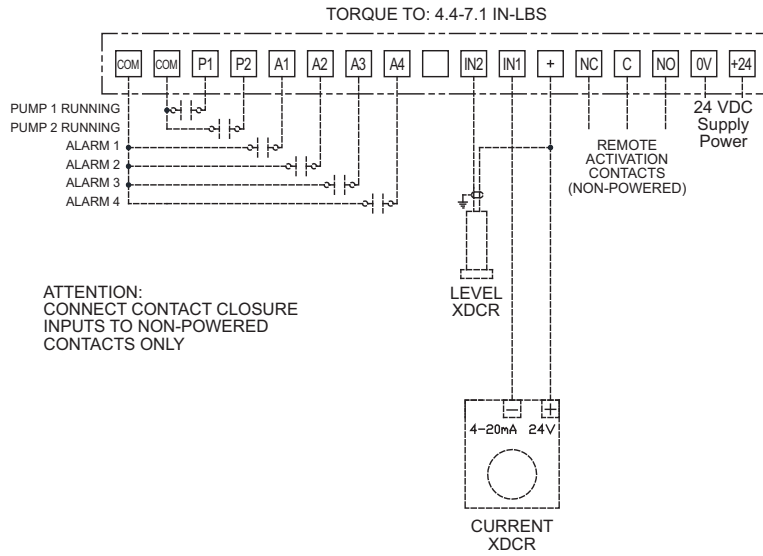
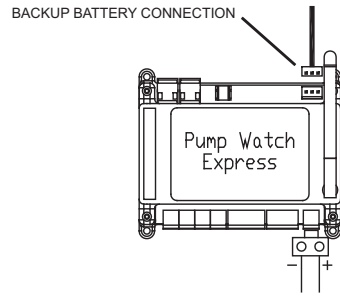

PUMP WATCH™ EXPRESS LIGHT RTU SCHEMATIC

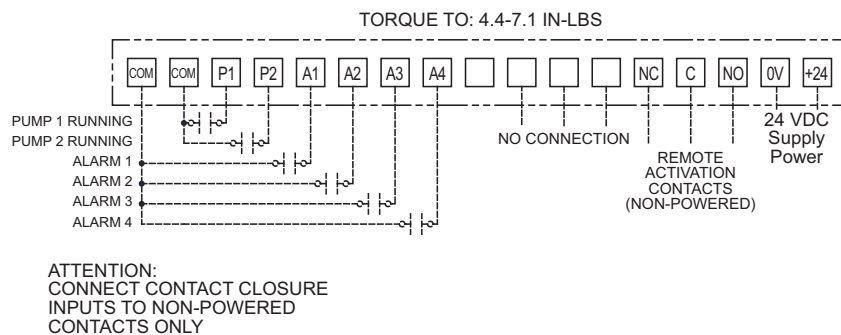
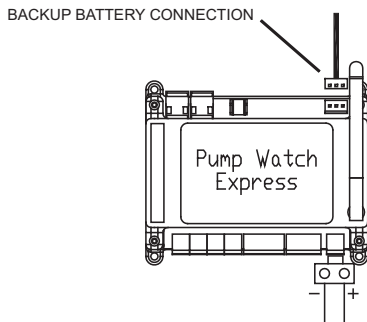

PUMP WATCH™ GATEWAY SCHEMATIC - VIEW CONTROLLER

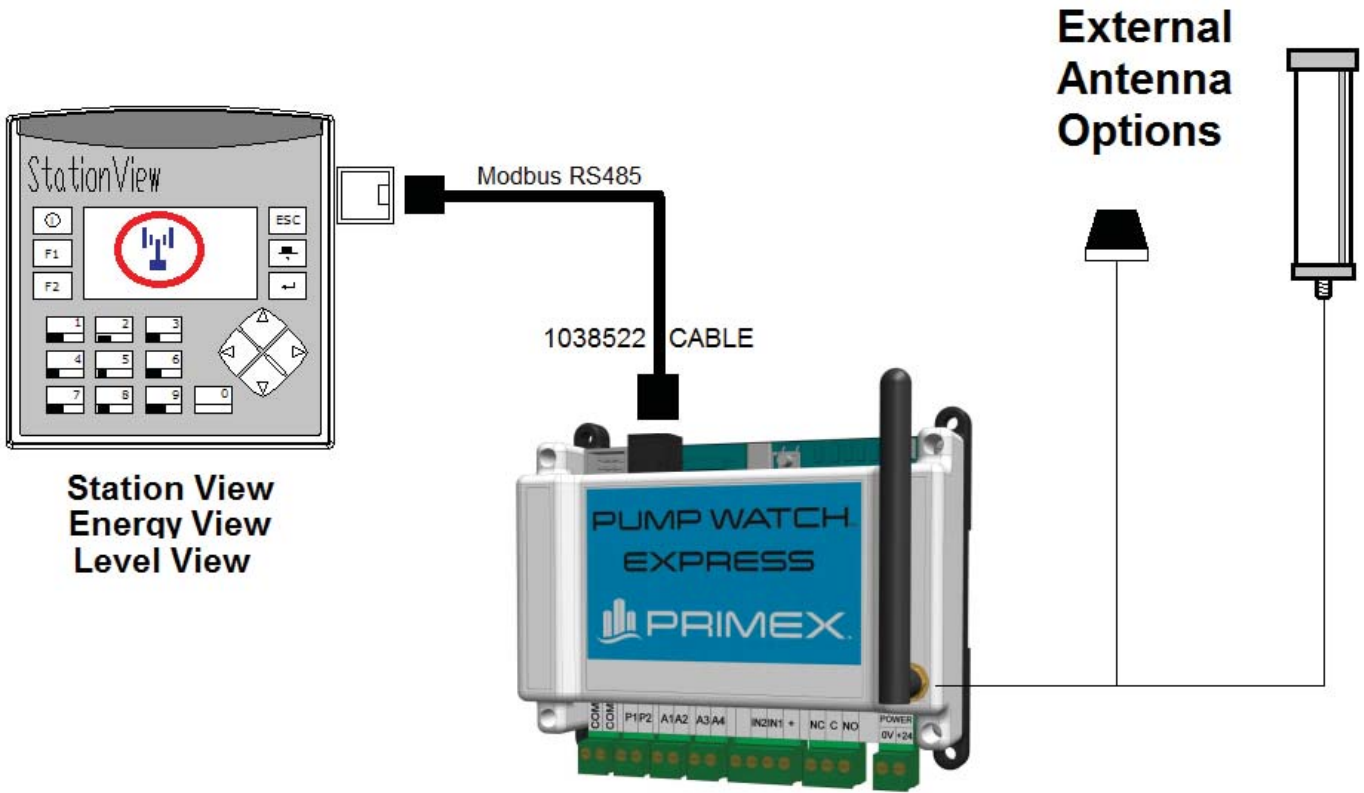

Station View
Energy View
Level View

1038522 CABLE ASSY, PUMP WATCH, SERIAL, 6 FT

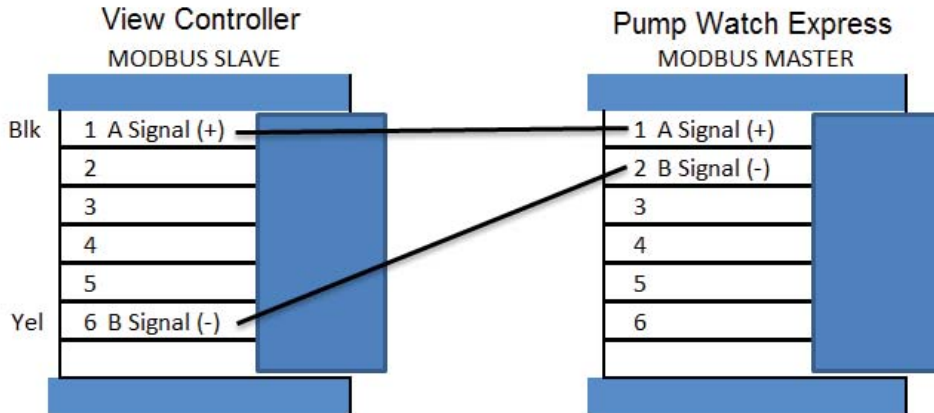

PUMP WATCH™ GATEWAY SCHEMATIC - PC-3000X CONTROLLER

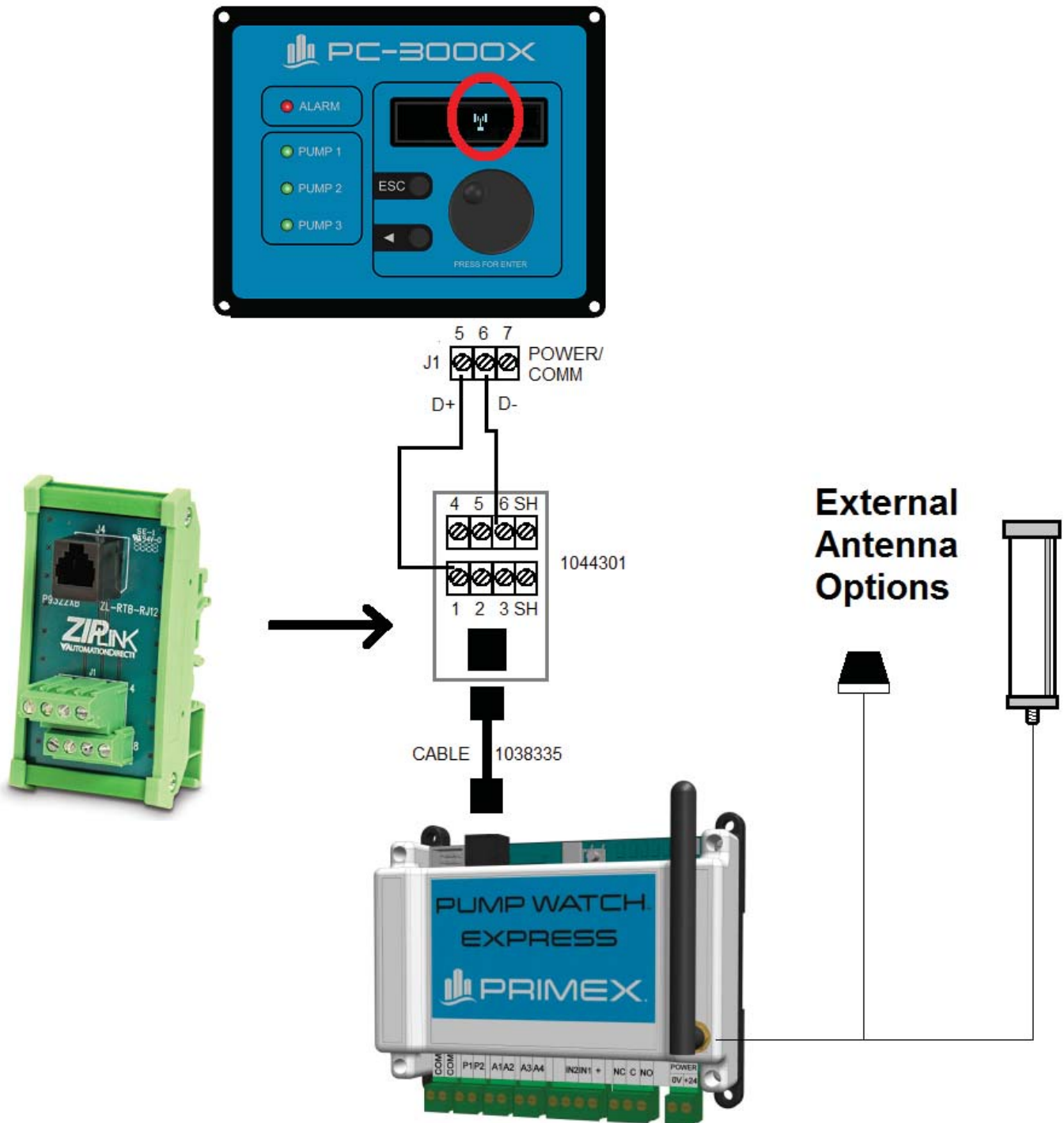

When using the Pump Watch Express Gateway with the PC-3000X controller, the following functions are not available:

- Current monitoring (there is no analog input on the controller for motor Amps).
- Today's Cycle Starts and Runtime. The previous 24h total is displayed (the controller does not have Real Time Clock).

SENSOR WIRING

CURRENT SENSOR EXAMPLE

Connect the current transducer as shown on the schematics. Open the core of the current transducer by pressing on the lever. Ensure that one (1) incoming power conductor passes through the center of the current transducer.

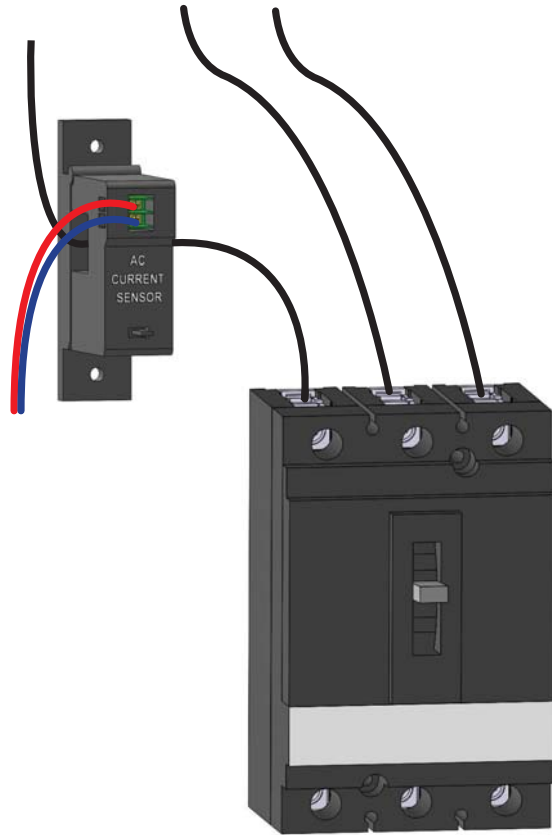

*Premium version only

PUMP RUN SIGNAL EXAMPLE

Wire the pump run inputs to a non-powered auxiliary contact in the control panel, which closes when the pump is called to run. These must be wired for each pump.

Motor contactor auxiliary contacts for reference only. Actual contactor configuration may differ.

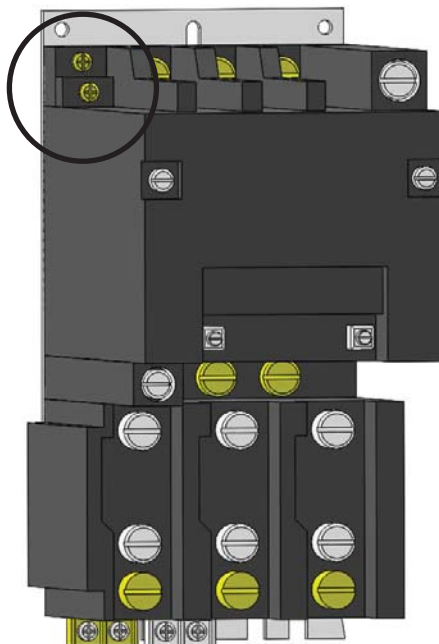

MOUNTING THE PUMP WATCH™ EXPRESS PANEL

Mount the Pump Watch™ Express panel using a solid base such as treated posts with a treated plywood overlay. Mounting on Unistrut or other metal structure is also common. Please use the appropriate hardware for securely anchoring the panel to the metal structure.

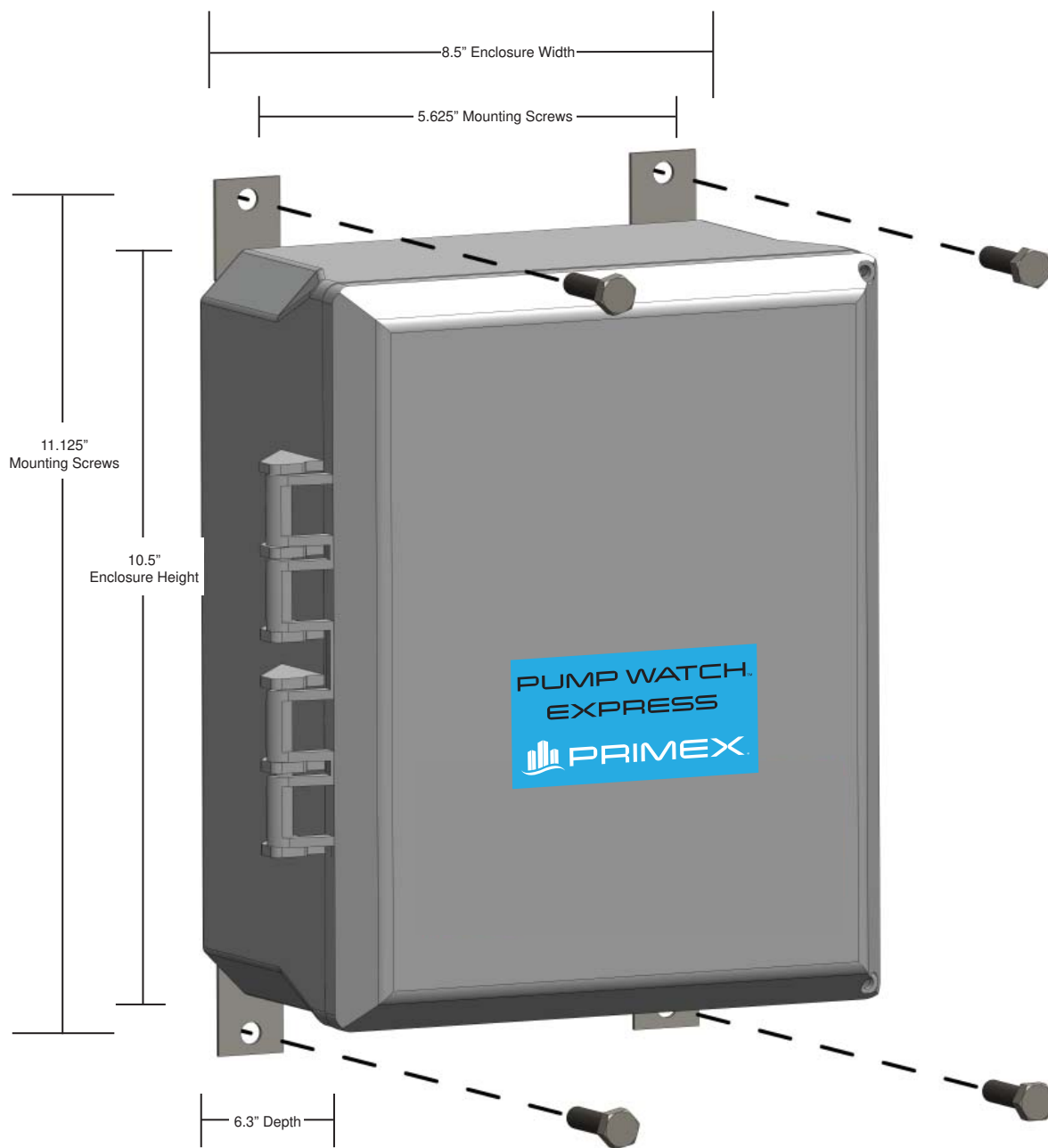

WIRING METHODS

When wiring the Pump Watch™ Express panel, be sure to use liquid-tight conduit or strain relief fittings.

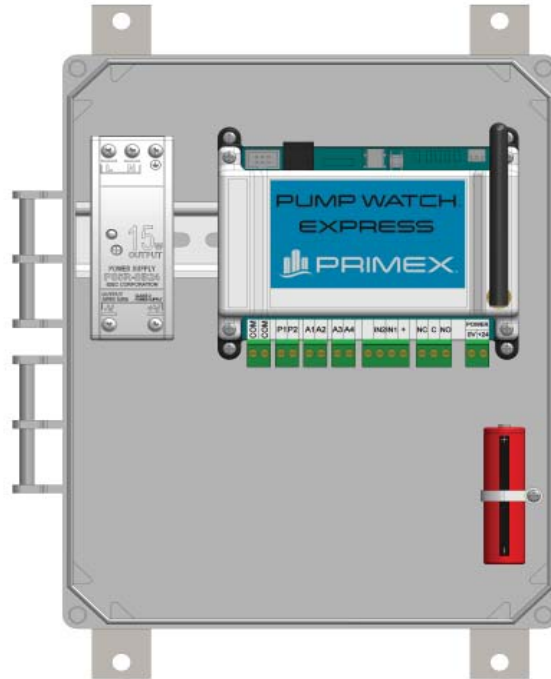

CONDUIT OPTIONS



Liquid-tight
conduit fittings



Liquid-tight conduit

OR



Conduit

Use liquid tight fittings and conduit to run cables between the Pump Watch™ Express and the Lift Station control panel. Do not run conduit from the Pump Watch™ Express to the wet well.

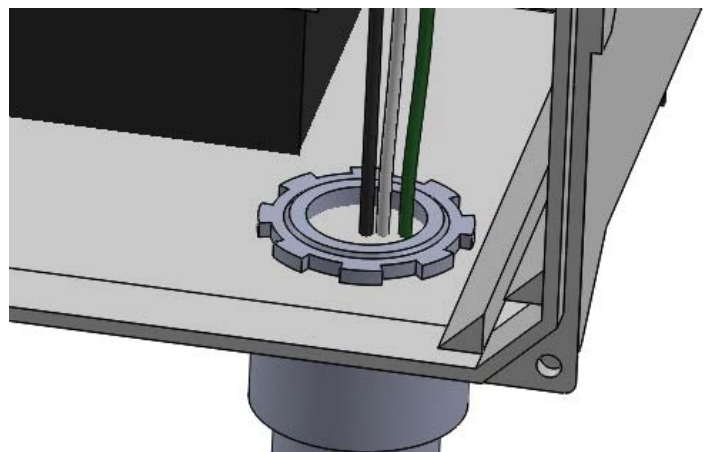
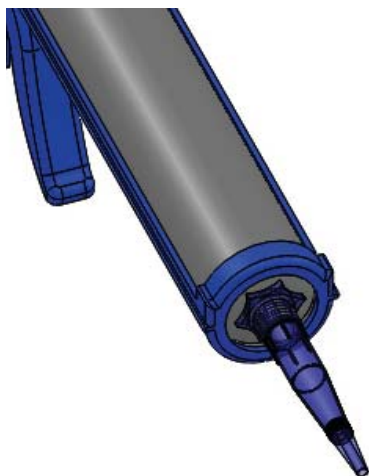

SYSTEM VIEW

PUMP WATCH™ EXPRESS INSTALLATION EXAMPLE

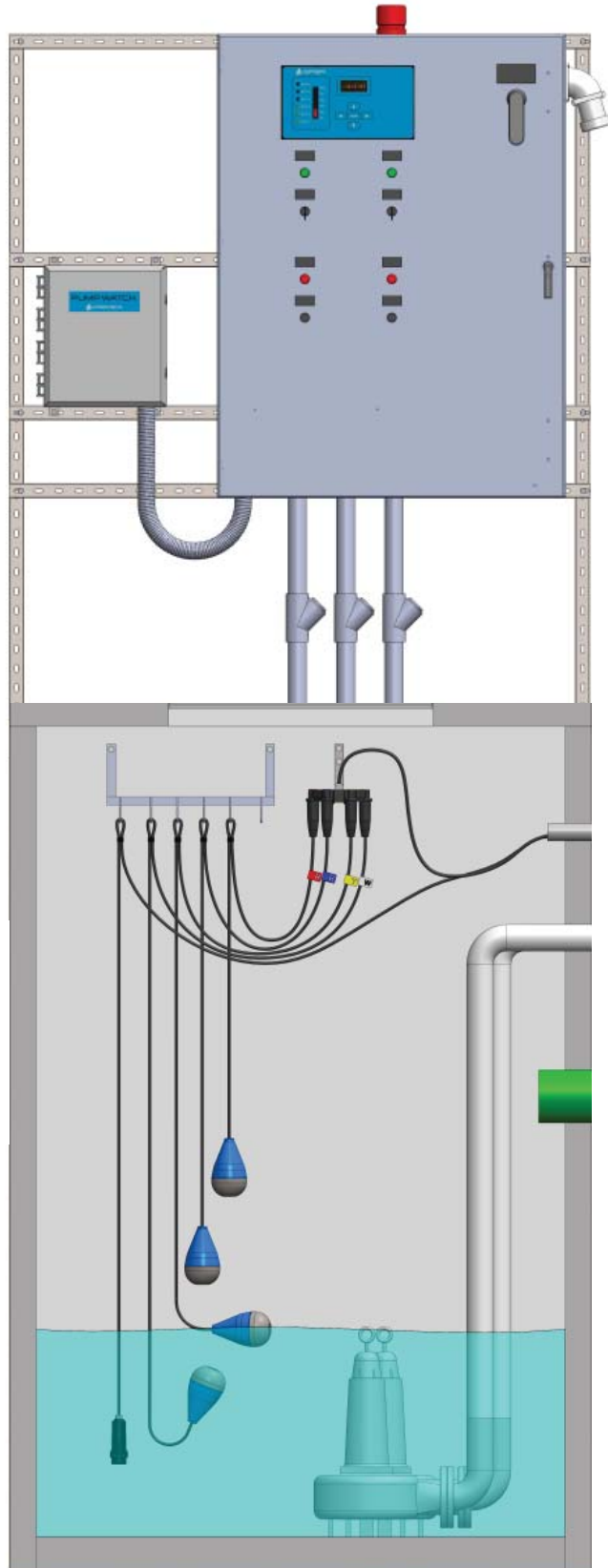

SCHEMATIC

100-240VAC INCOMING POWER

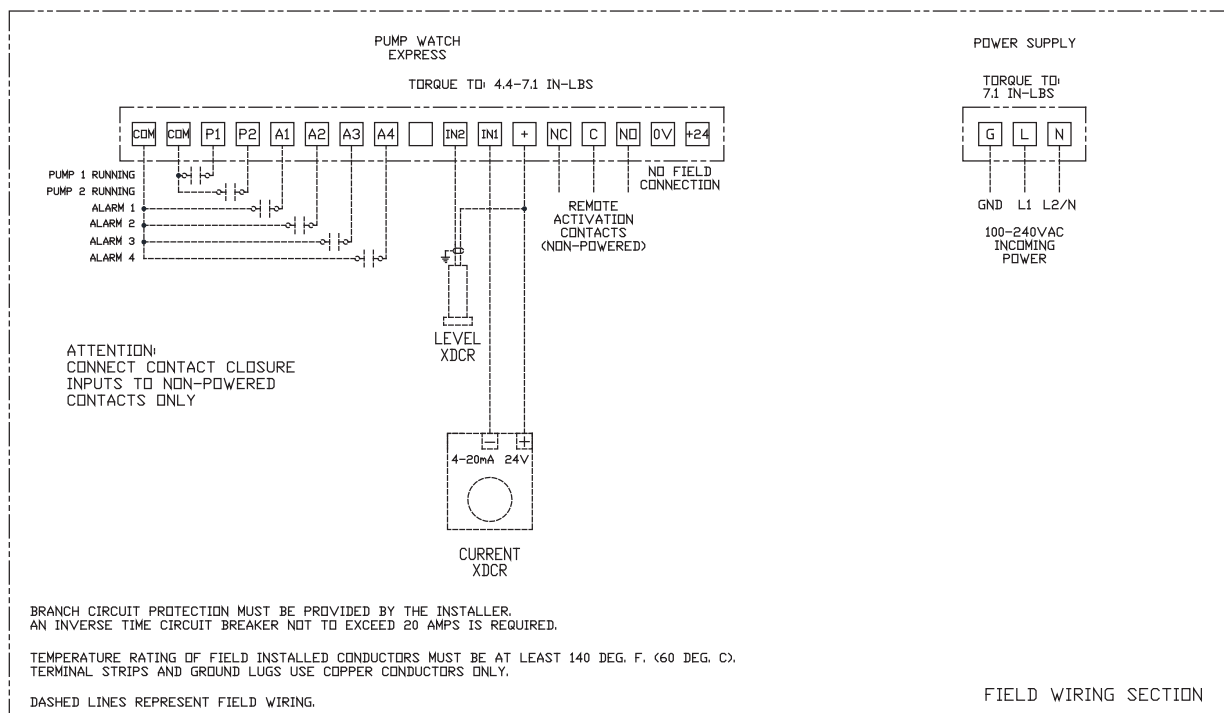
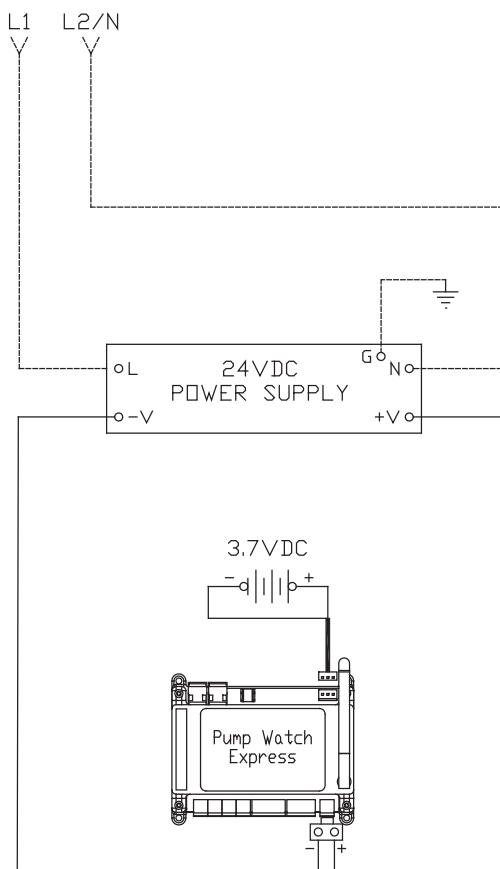

* PumpWatch™ Express Premium is shown above. See pages 8 and 9 for additional versions.

PUMP WATCH™ EXPRESS TROUBLESHOOTING

Indicating LED on the Pump Watch™ Express RTU

Function LED (top of RTU)

LD12 Green - External power (24Vdc). (Right)

LD1 Green - Cellular Modem Power.

LD2 Blue - Connecting to Cellular network (on power up).

LD3 Red - Alarm/Fault present (LIGHT or PREMIUM)

LD4 Yellow - Heartbeat Flash = ONLINE. Fast Flash = OFFLINE

I/O Status LED at the bottom of the RTU

Each input has a corresponding LED indicator above the input terminal

The relay output also has an LED indication.

(See page 12 for details.)

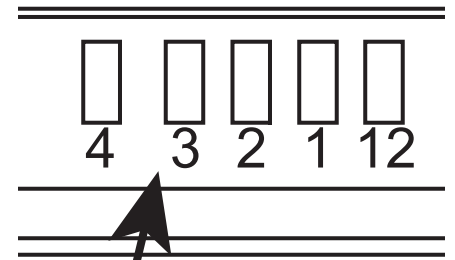

Function LED's

RTU COMMUNICATION

The user can check the RTU signal strength (RSSI) on the web portal. Hover your cursor over the signal strength icon on the top of the main screen.



RSSI THRESHOLDS

RSSI is a measurement of the power present in a received radio signal (**R**eceived **S**ignal **S**trength **I**ndicator). The larger the number, the better the reception.

Below is a guideline to appropriate strength thresholds:

1-5 = very poor (no communication)

6-8 = poor (inconsistent communication)

9-11 = good (little to no communication issues)

>12 = best

LOGGING IN

Click on the following link or type in the following URL in your browser to open the login screen.
<http://www.primexlogin.com>

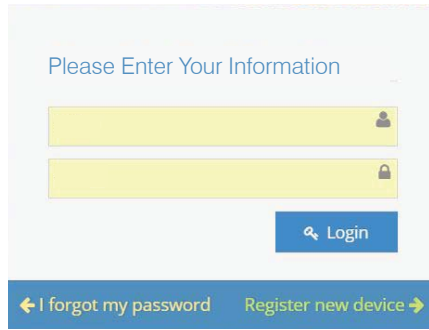

Google Chrome or Mozilla Firefox are the recommended web browsers.

Can also be accessed at www.primexcontrols.com



CUSTOMER SERVICE AGREEMENT AND TERMS OF USE

This agreement outlines the agreement between AMI and the end User and must be agreed to before access to the cloud interface is allowed.

An automatic email is generated and sent to the email address you entered. Follow the link in the email to verify and activate your account.

After logging in again, you will need to agree to the Terms of Use. These steps only need to be completed during the initial setup and activation of your account.

Notes:

The end User should activate this product. When the initial 1 year of cellular service comes to an end, AMI will contact you directly and review renewal options. The primary User (Account Admin) will be able to add additional Users for login and alarm notification. The cellular service plan provided with the Pump Watch™ only covers text (SMS), and data for the Pump Watch™ Express unit. It does not cover SMS and Data service charges incurred for the use of your personal cell phone or tablet.

ACCESS LEVELS

The portal has three (3) access levels.

- Dealer
- **Account Admin**
- User

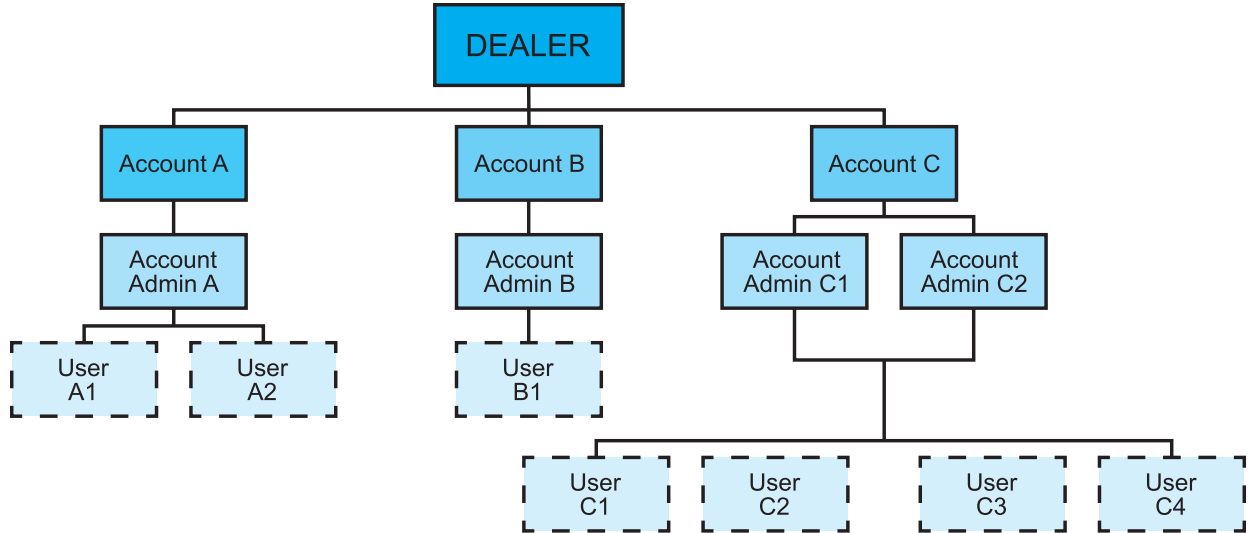

Note! You may have multiple Account Admins and Users per account, but each Account Admin or User can only be assigned to one Account.

| | Create Accounts | Create Account Admins | Create Users | Assign Gateways to Accounts | Place Gateways on Map ¹ | Configure Gateways ² | Name Gateways | Search Gateways | View Gateway Data | Run Reports |
|----------------------------|-----------------|-----------------------|--------------|-----------------------------|------------------------------------|---------------------------------|---------------|-----------------|-------------------|-------------|
| Dealer | X | X | X | X | X | X | X | X | X | X |
| Account Admin ³ | | | X | | X | | X | X | X | X |
| User | | | | | | | | X | X | X |

¹ With privileges assigned

² With privileges assigned

³ Account Admin and User can work within assigned account only

VIEWING/SEARCHING FOR YOUR DEVICE

After you complete the registration procedure, you have access to your account and all of the RTUs contained within. There are multiple ways to search for/find/select a controller.

- From Map (Satellite or road view available)
- From List
- From Tree View
- Search by RTU Name or ID
- Sort by RTU Name or ID

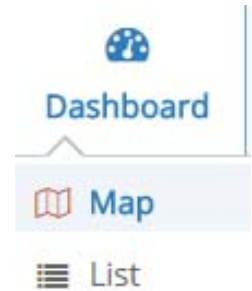

FROM MAP

When you log in, the interactive map appears on the main screen. If your RTU(s) have already been located on the map, it will appear here (the next section explains how to place the RTU on the map). Click on a controller to see the device ID and other pertinent information.

To select an RTU, click on the RTU icon.

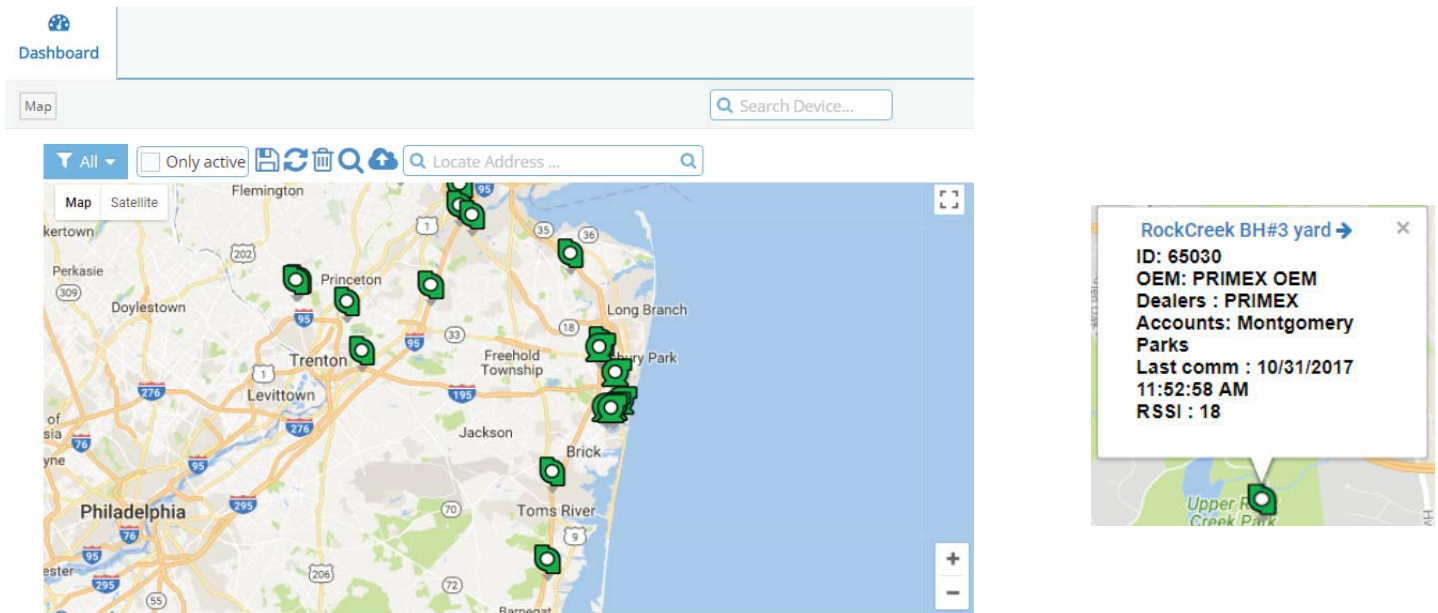

FROM LIST

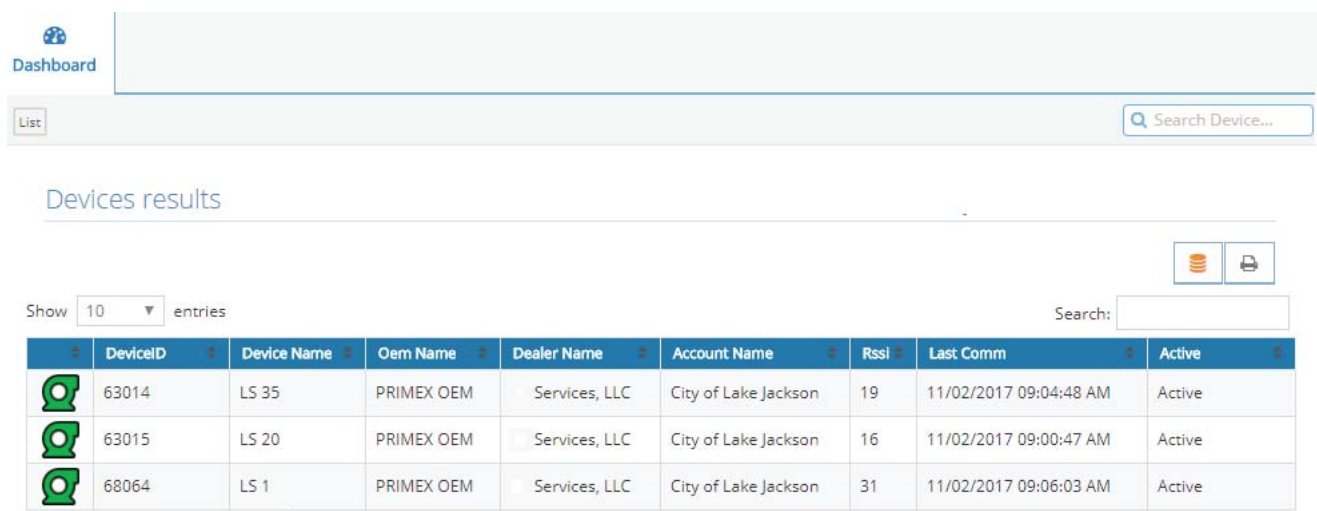





FROM TREE VIEW

On the left side of the window, all RTUs in the account are permanently displayed and can be clicked at any time to move from one RTU to another.

To select an RTU from the Tree View, click on the RTU icon.

-  60013 PWE-L 3G
-  60014 PWE-L 3G
-  60016 PWE-L 3G
-  60018 PWE-L 3G
-  60019 PWE-L 3G
-  60025 PWE-L 3G
-  65056 PWEL CDMA
-  65100 PWE-L CDMA

Pump Watch Icons

- PW Express (Off-line) —  Premium RTU
- PW Express (On-Line) —  Premium RTU
- Pump Watch (Off-line) —  Gateway
- Pump Watch (On-line) —  Gateway
- PW Express (On-line) —  Light RTU



SEARCHING AND SORTING BY RTU ID OR NAME





Select the “List” view from the Dashboard to search devices based on any of the top row items: Device ID, Device Name, Account Name, etc.

Dashboard

List

Devices results Enter ID # or Device name

Show 10 entries Search: 65  

| DeviceID | Device Name | Oem Name | Dealer Name | Account Name | Rssi | Last Comm | Active | |
|---|-------------|----------------------|-------------|--------------|------------------|-----------|------------------------|--------|
|  | 65000 | 65000 Liftstation #2 | PRIMEX OEM | PRIMEX | City of Gibbon | 9 | 11/02/2017 09:24:39 AM | Active |
|  | 65001 | 4" rental pump | PRIMEX OEM | PRIMEX | Sander | 20 | 11/02/2017 10:24:27 AM | Active |
|  | 65002 | Oceanview P.S. | PRIMEX OEM | PRIMEX | Stantec - GSP | 14 | 11/02/2017 10:25:11 AM | Active |
|  | 65003 | lift station 01 | PRIMEX OEM | PRIMEX | City of Poteau | 16 | 11/02/2017 09:24:16 AM | Active |
|  | 65004 | RockCreek BH#2 Ape | PRIMEX OEM | PRIMEX | Montgomery Parks | 22 | 11/02/2017 10:25:07 AM | Active |

PLACING AN RTU ON THE MAP

Account Administrators can place individual controllers on the map interface powered by Google Imagery.

PLACING A CONTROLLER ON THE MAP (Dashboard - Map View)

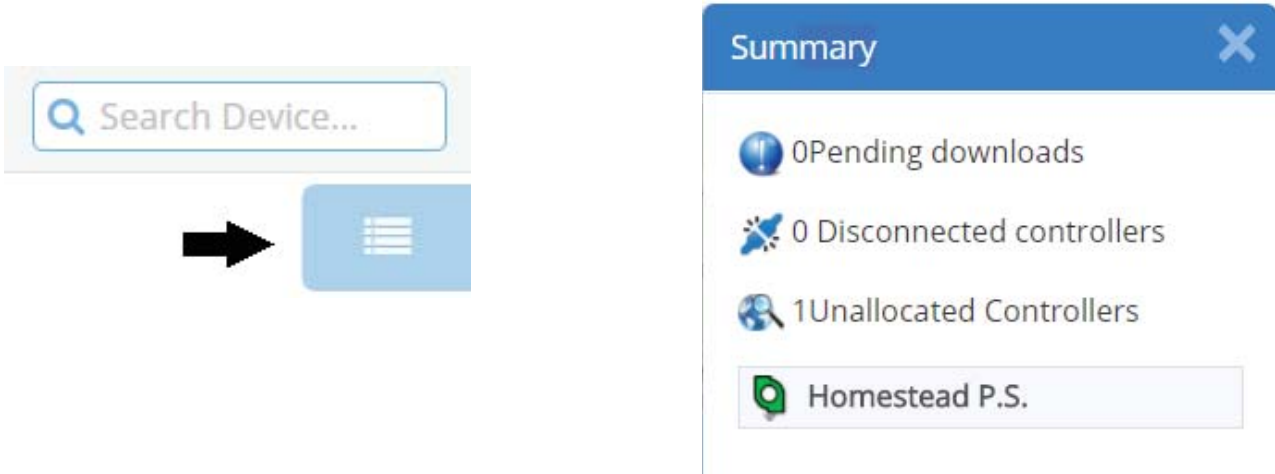

- Click and release the unallocated device, then click on the map to drop. Drag and drop to the desired location then save.

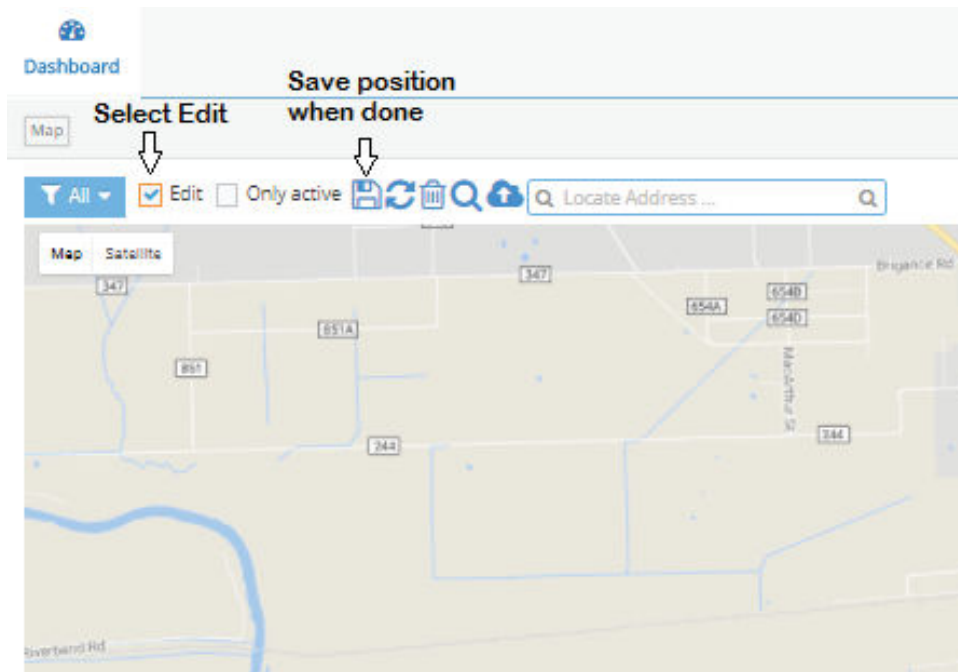

USER SETUP

As an Account Admin, you can create/edit/delete Users, but not other Account Admins. To set up additional Account Admins, you need to contact the Dealer level admin or AMI support.

NEW USER SETUP

- Click  at the top right of the page and select Users.

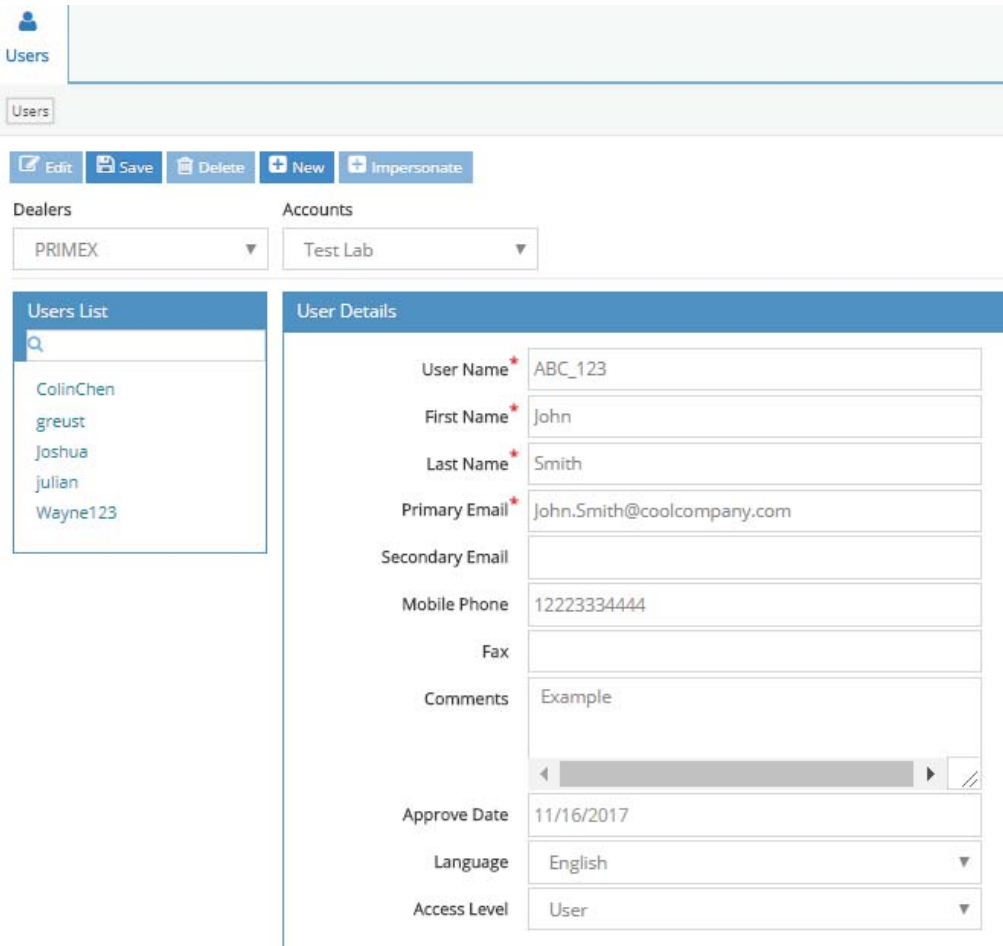

The screenshot displays the 'Users' management interface. At the top, there is a 'Welcome,' dropdown menu. Below it, there are buttons for 'Edit', 'Save', 'Delete', 'New', and 'Impersonate'. There are also dropdown menus for 'Dealers' (set to PRIMEX) and 'Accounts' (set to Test Lab). The main content area is divided into two sections: 'Users List' and 'User Details'. The 'Users List' section shows a search bar and a list of users: ColinChen, greust, Joshua, julian, and Wayne123. The 'User Details' section shows a form with the following fields: User Name (ABC_123), First Name (John), Last Name (Smith), Primary Email (John.Smith@coolcompany.com), Secondary Email, Mobile Phone (12223334444), Fax, Comments (Example), Approve Date (11/16/2017), Language (English), and Access Level (User).

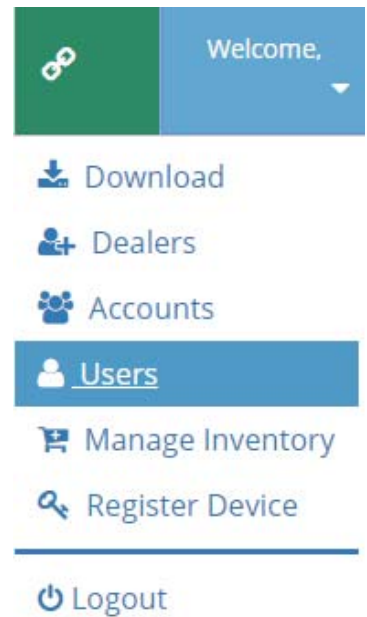

The screenshot shows the top right navigation menu. It includes a 'Welcome,' dropdown menu, followed by links for 'Download', 'Dealers', 'Accounts', 'Users' (which is highlighted), 'Manage Inventory', 'Register Device', and 'Logout'.

Once a new user account is created, an email will be sent to the new user's email address. The user will have 48h to use the link on the email to verify the information listed above. This verification process is in place to ensure that new users are aware and willing to receive future alarm notifications. If the user account is not verified, the notification will not be sent to that user.

DASHBOARD

Ensure that the RTU has been properly configured. The functionality of this system is dependent on the setup of the RTU.

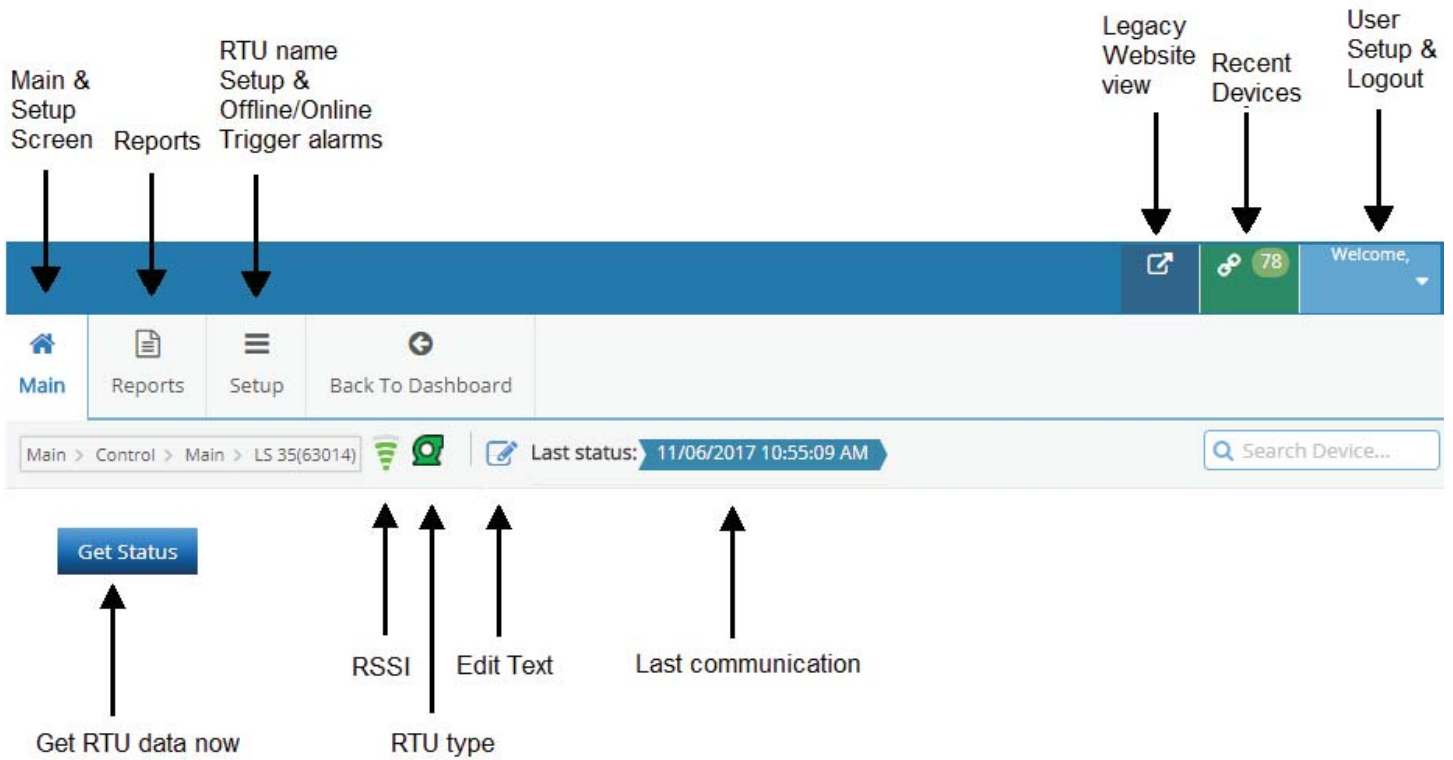

*The data on the screen may not display the latest RTU values. Use the "Get Status" button to read the most current values.

RTU SETUP

Click on the Setup button on the top row of the Main Screen to enter the RTU edit screen.

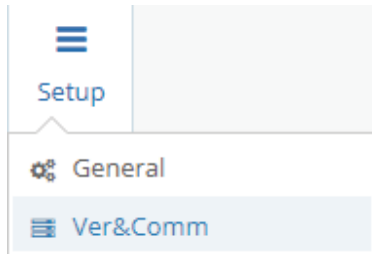

General Setup

A screenshot of the 'General Setup' screen for an RTU. The screen has a top navigation bar with 'Main', 'Reports', 'Setup' (highlighted), and 'Back To Dashboard'. Below the navigation bar is a breadcrumb trail: 'Setup > General > LS 35(63014)'. There are three action buttons: 'Save', 'Clear pending messages', and 'Get Cell Tower Position'. The main content area contains several fields: 'ID' (63014), 'Name' (LS 35), 'Dealers' (Big Pump House), 'Accounts' (Large City), 'Time zone' ((GMT-06:00) Central Time (US & Canada)), 'Day Light Saving' (0), 'Latitude' (29.0285587310791), 'Longitude' (-95.4572601318359), and 'Refresh Interval [sec]'. A 'Set Clock' button is located below the Day Light Saving field. A trash icon is next to the Latitude field.

Same as the ID# on the RTU unit.
This number cannot be edited

Enter Station Name. You do not need to
enter the account name. It will be included
in the notification automatically.

GPS location may be entered here or
the unit maybe dragged and drop on the
map at the correct location

Click  to store changes. It will take a few seconds to take effect.

ONLINE/OFFLINE TRIGGER ALERT SETUP

The Pump Watch™ Express has the ability to alert the user when the RTU transitions from online to offline and offline to online. Click on the **Ver&Comm** tab on the setup screen to setup the online and offline triggers.

Ver & Comm Setup

The screenshot displays the 'Ver & Comm Setup' interface. At the top, there are navigation tabs: 'Main', 'Reports', 'Setup' (highlighted), and 'Back To Dashboard'. Below the tabs is a breadcrumb trail: 'Setup > Ver&Comm > LS 35(63014)'. A 'Get Status' button is located below the breadcrumb. The main content area is divided into two sections: 'Versions' and 'Server Alerts'.

Versions

| Versions | |
|------------------|----------------------|
| VAPOR version | 18.14 |
| Hardware version | 2.1 |
| Modem version | 12.24 |
| RSSI | 19 |
| Cell ID | 2812 |
| SIM | 8934071179003596960 |
| IMEI | 351579054557184 |
| Last Comm | 11/6/2017 4:35:11 PM |
| Developer Code | 0 |

Server Alerts

Save

| Active | Name | Text | Email |
|-------------------------------------|------------------|---|--------------------------|
| <input checked="" type="checkbox"/> | OfflineTriggered | <input type="text" value="OfflineTriggered"/> | <input type="checkbox"/> |
| <input type="checkbox"/> | OnlineTriggered | <input type="text" value="OnlineTriggered"/> | <input type="checkbox"/> |

See page 31 for more information on ALARM NOTIFICATION SETUP.

The Online Triggered notification will alert the selected user when the RTU is connected to the cellular network and transmitting to the server.

The Offline Triggered notification will alert the selected user if the RTU is no longer On-line (not connected to the server). This can be as a result of power loss for a prolonged time, or a drop in cellular service. It can take the server up to 20 minutes to detect this condition.

RTU VISUALIZATION

Several templates are available to visualize your remote controller. There is a unique template for the Light, Premium, and Gateway. A custom template can also be designed for special applications. The template shown below is for the Premium.

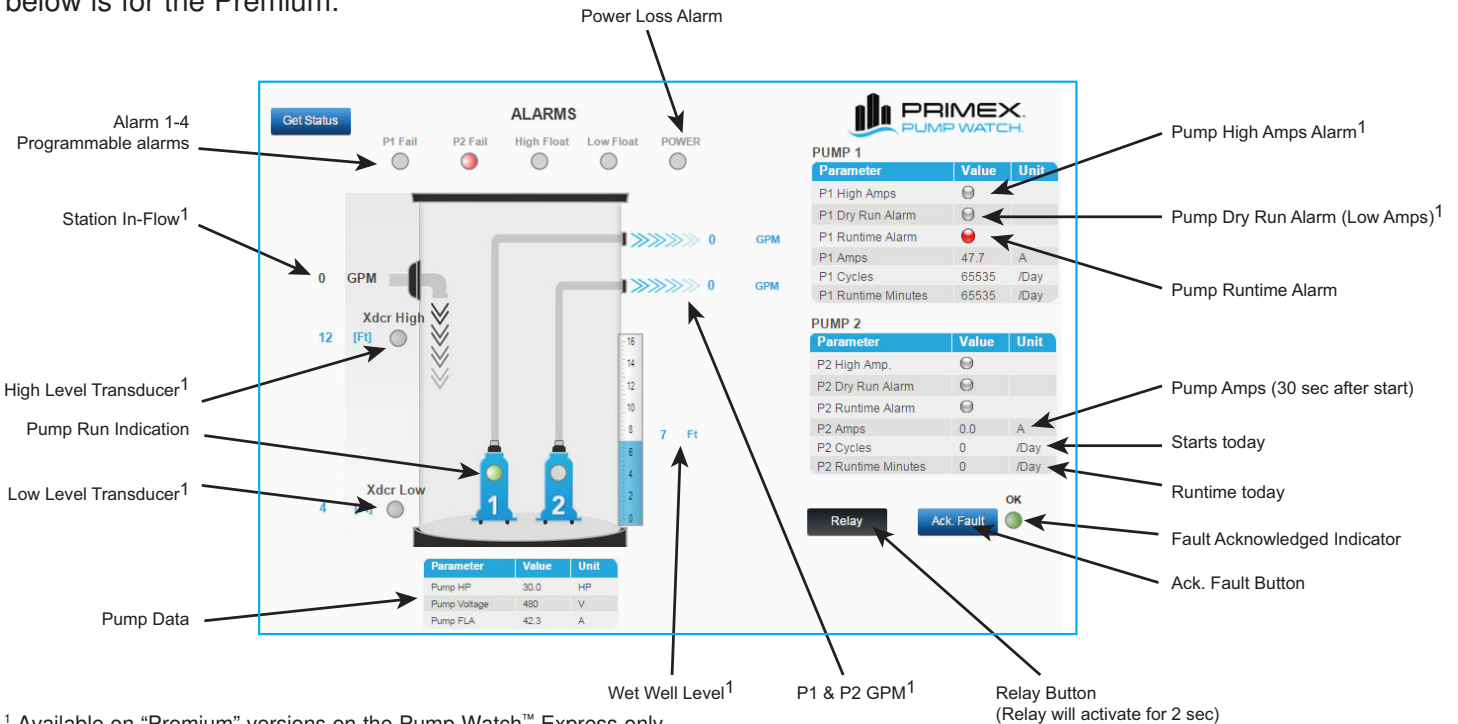

ALARMS

Light Version

Alarm 1-4: These alarms become active upon a contact closure (see wiring schematics). The label "Alarm 1" can be changed to describe the actual alarm condition. Example: "P1 Fail". (See pg. 27 for instruction on how to edit text on the Main Screen.)

LED indication: The LED indication on the screen will turn red when the alarm is active. You can configure the alert notification by clicking on the indicator.

Power: If 24 Vdc power is lost for more then the set time (see Configuration screen). The 3.7 Vdc battery must be connected.

P1-2 Runtime Alarm: The pump ran continuously for longer than the set time (see Configuration screen). This condition may indicate a pump clog, a high in-flow event, or sensor fault.

Premium Version Additional Alarms

Xdcr High: Level transducer High Level alarm. This alarm set point and timer value is set in the configuration screen. The tank level value will go zero if 24 Vdc power is lost and the RTU keeps running on the 3.7V Li ion battery. The High Level alarm will no longer be active during this condition. It is recommended to have a 24 Vdc battery back up system to ensure alarm notification during power loss. Alternately, a high level float switch may be connected to any of the 4 digital alarms and activate during power loss.

Xdcr Low: Level transducer Low Level alarm. This alarm set point and timer value is set in the configuration screen. This alarm will not be active on power loss (24 Vdc), and running on the 3.7V Li ion battery.

P1-2 High Amps: The pump running amps are higher than set point for longer than the set timer (see Configuration screen). Not available with the PC-3000X controller.

P1-2 Dry Run Alarm: The pump running amps are lower than set point for longer than the set timer (see Configuration screen). Not available with the PC-3000X controller.

RELAY BUTTON

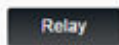

By pressing the **REMOTE START** on the screen, you will remotely energize the relay in the RTU. The relay will only stay ON for 2 seconds, then it will turn OFF automatically. The label text below the relay button can be edited to describe the function of the relay. Example: "Silence Horn".

CAUTION/DANGER

Machine may start unexpectedly and cause serious injury or death. You must have confirmation that all personnel are free and clear from moving parts and the electrical panel before activating the relay remotely.

Only allow qualified operators to remotely activate the relay. The relay remote operation must be part of a fail safe electrical circuit that would shutdown the equipment before failing or cause damage/injury.

Local and National safety codes must be followed.

ACK. FAULT BUTTON AND INDICATION

The **Ack. Fault** button must be pressed after an alarm within the set time (See Setup screen). If an alarm becomes active, the timer starts and the operator must acknowledge the alarm on the screen before the timer times out (default value is 20 min). If not acknowledged the OK indicator turns **red** and can be used to notify other users of the failure to acknowledge. This function is useful if only one user is on standby, and may not be able to respond in a timely manner. Click on  to set the Alert notification. Leave it blank if you do not wish to use this function.

STATION DATA (trending available - see Report & Trending section)

Wet Well Level: Level of the wet well as measured by the transducer.

P1-2 Amps: Pump Current snapshot captured 30 secs after motor start by the current transducer. Not available when using the PC-3000X controller.

P1-2 Cycles: The number of start cycles occurred since midnight. Note: When using the Pump Watch™ Express Gateway with the PC-3000X controller, this value is the previous 24h accumulated cycle counts.

P1-2 Runtime Minutes: Accumulated motor run since midnight. View reports (accumulation for full run analysis day/week/month. Note: When using the Pump Watch™ Express Gateway with the PC-3000X controller, this value is the previous 24h accumulated Runtime.

Station In-Flow (GPM): The measurements are calculated using the wet well level, the tank diameter and the fill time. It is very useful data point in tracking peak flow hours and to detect storm water infiltration issues.

P1-2 GPM: The measurements are calculated using the wet well level, the tank diameter, the fill time and discharge time. It is a very useful data point in tracing the performance on each pump, and to understand the effect of changing head conditions.

Pump Data: These values are not measured. They are used as reference and for record keeping. It is valuable to compare the pump FLA to the actual Amps on the screen for setting High Amp and Dry Run Alarms. It is also a quick way to check the pump data before making a service call to the station.

MAIN SCREEN CONFIGURATION

MAIN SCREEN - Editing Text Labels

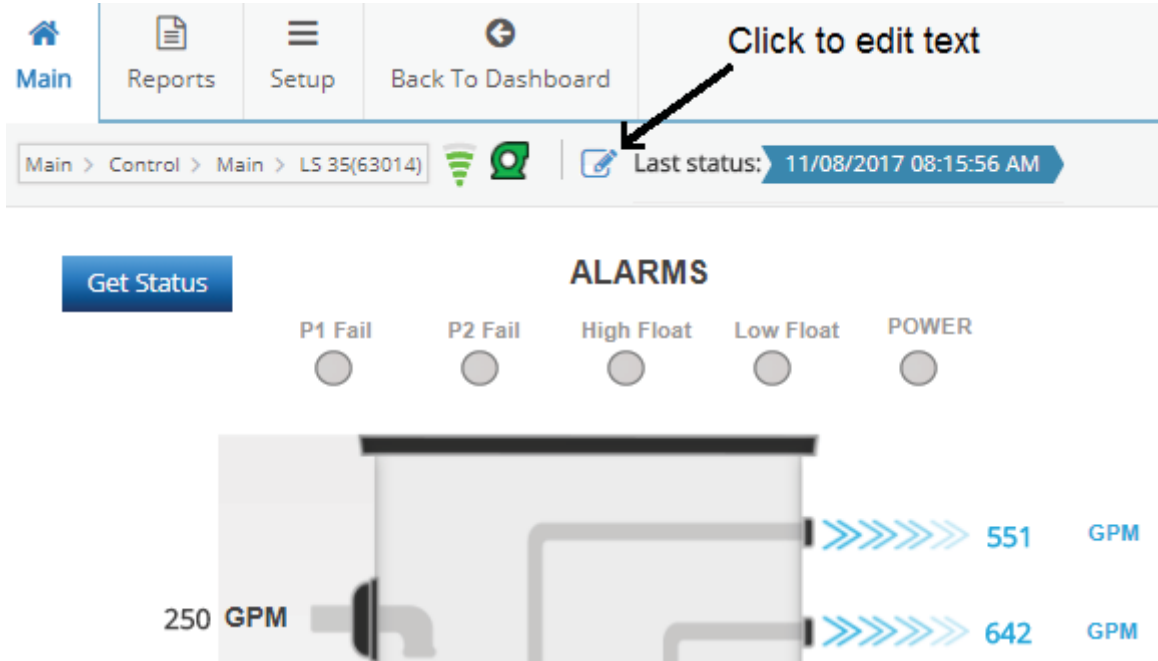

This function enables you to change the text on the screen to match the function of the alarm assigned in the field. Example:

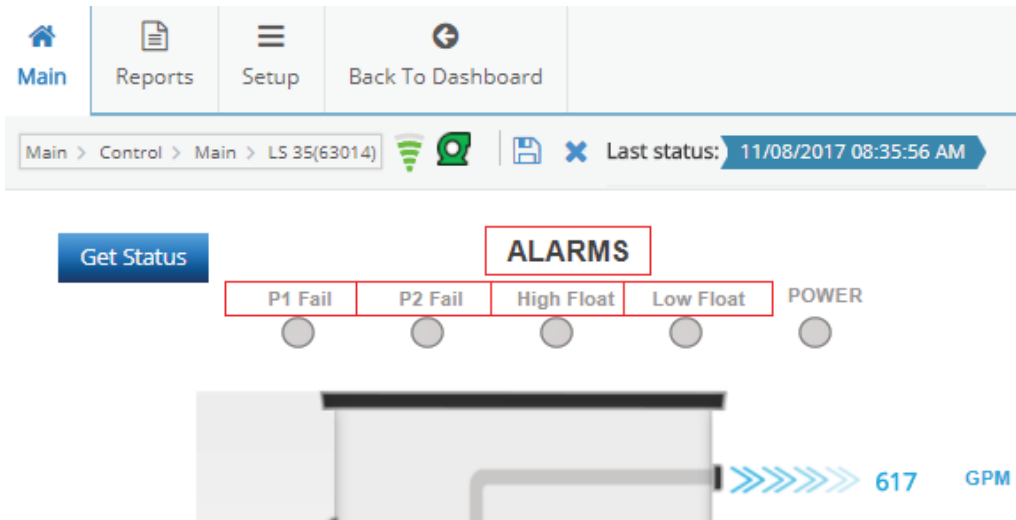

You can now edit the text labels with the **red** boxes.

To save changes press  , to cancel edits press  .

STATION PARAMETER CONFIGURATION

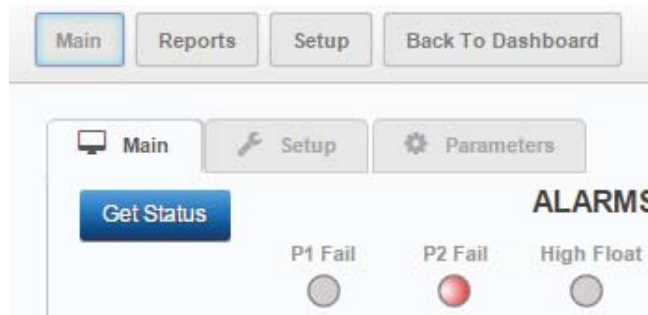

Click on  to navigate to the parameter Setup screen. This screen is not available when using the Gateway, as these set points are entered in the controller it is connected to.

| Get Parameters | | | Save |
|-----------------------------|-------|------|------|
| Parameter | Value | Unit | |
| Alarm 1 delay | 60 | Sec | |
| Alarm 2 delay | 60 | Sec | |
| Alarm 3 delay | 2 | Sec | |
| Alarm 4 delay | 0 | Sec | |
| Power loss Alarm delay | 0 | Sec | |
| High Tank Level Alarm delay | 0 | Sec | |
| Low Tank Level Alarm delay | 0 | Sec | |
| Acknowledge Alarm Delay | 0 | Min | |



| Level Sensor Setup | | | Save |
|--------------------|-------|------|------|
| Parameter | Value | Unit | |
| Range (20mA) | 34.7 | Ft | |
| Offset | 1.0 | Ft | |

| Current Sensor Setup | | | Save |
|----------------------|-------|------|------|
| Parameter | Value | Unit | |
| Range (20mA) | 100.0 | A | |

| Alarm Setup | | | Save |
|------------------|-------|------|------|
| Parameter | Value | Unit | |
| High Tank Level | 11.0 | Ft | |
| Low Tank Level | 2.5 | Ft | |
| P1 Max Runtime | 0 | Min | |
| P2 Max Runtime | 0 | Min | |
| P1 High Amp | 60.0 | A | |
| P2 High Amp | 60.0 | A | |
| P1 Dry Run | 37.0 | A | |
| P2 Dry Run | 37.0 | A | |
| P1 Dry Run Delay | 10 | Sec | |
| P2 Dry Run Delay | 10 | Sec | |

| Flow Monitoring Setup | | | Save |
|------------------------|-------|------|------|
| Parameter | Value | Unit | |
| Tank Diameter | 10.4 | Ft | |
| Flow Calc. Start Level | 5 | Ft | |
| Flow Calc. Stop Level | 4 | Ft | |

| Pump Data | | | Save |
|--------------|-------|------|------|
| Parameter | Value | Unit | |
| Pump HP | 25.0 | HP | |
| Pump Voltage | 230 | V | |
| Pump FLA | 60.0 | A | |

| PARAMETER | PURPOSE | DEFAULT VALUE |
|------------------------------------|--|---------------|
| Alarm 1-4 delay | Delay timer used to confirm the presence of a closed contact. | 2 Sec |
| Power loss Alarm delay | Delay timer used to confirm the loss of the 24Vdc power supply. | 30 Sec |
| High Tank Level Alarm delay | Delay timer used to confirm the presence of a high level measurement from the transducer. This alarm is triggered by the High Tank Level value. | 5 Sec |
| Low Tank Level Alarm delay | Delay timer used to confirm the presence of a low level measurement from the transducer. This alarm is triggered by the Low Tank Level value. | 5 Sec |
| Acknowledge Alarm delay | If an alarm becomes active, the timer starts, and the operator must click the  button on the screen before the timer times out. If not acknowledged, the  indicator turns red and can be used to notify other users of the failure to acknowledge. This function is useful if only one user is on standby, and may not be able to respond in a timely manner. | 20 Min |

Press  after edits to store values to the RTU.

STATION PARAMETER CONFIGURATION

LEVEL SENSOR SETUP (sold separately for Premium RTUs)

| PARAMETER | DEFINITION | DEFAULT VALUE |
|---------------------|---|---------------|
| Range (20mA) | Level transducer measurement range. Value in Ft for 20mA output | 15 Ft. |
| Offset | Level transducer distance above the bottom of the tank. This value is added to the measurement. | 1 Ft. |



CURRENT SENSOR SETUP (supplied with Premium RTUs)

| PARAMETER | DEFINITION | DEFAULT VALUE |
|---------------------|--|---------------|
| Range (20mA) | Current transducer measurement range. Value in A for 20mA output | 100A |



ALARM SETUP

| PARAMETER | DEFINITION | DEFAULT VALUE |
|--------------------------|---|---------------|
| High Tank Level | High level set point for transducer high level alarm | 12 Ft. |
| Low Tank Level | Low level set point for transducer low level alarm | 0 Ft. |
| P1-P2 Max Runtime | Max timer value for pump runtime during a single cycle. The RTU is equipped with a maximum run time indicator. The unit can be configured to activate a message if a pre-determined maximum run time, per pump cycle, has been exceeded. This alarm requires the user to click on the Ack. Fault to clear. | 30 min. |
| P1-P2 High Amp | Max timer value for pump runtime during a single cycle. The RTU is equipped with a maximum run time indicator. The unit can be configured to activate a message if a pre-determined maximum run time, per pump cycle, has been exceeded. This alarm requires the user to click on the Ack. Fault to clear. | 80A |
| P1-P2 Dry Run | Dry Run indication uses the motor current measurement to determine whether a pump is running dry (no load). For a submersible pump, the current draw will typically drop 30% from normal when running dry. Please consult your pump manufacture for this value and test this fault, if possible. The amp set value corresponds to the minimum amp value that the pump should draw during normal operation. If the current drops below this value for longer than the Dry Run Delay , the remote telemetry unit will display a “Dry Run” fault. The “trip Delay” time is used to avoid nuisance tripping. This alarm requires the user to click on the Ack. Fault button to clear. | 0A |

Note: Setting values to “0” in the alarm setup will disable the alarm function.

FLOW MONITORING SETUP (PREMIUM)

Volumetric flow measurement is available when a level transducer is used in a cylindrical tank. The Pump Watch™ Express unit calculates the volume of liquid based on the level. The flow is calculated by using the volume and the fill/discharge times. The in-flow and the discharge flow is measured. The Flow Calc. Level set points are not used for controlling the pump. They are used for volumetric flow calculation. The flow calculation is based on the diameter of the tank, the Start Flow Calc. and Stop Flow Calc. level set points, and the fill and discharge times. Both In-Flow and Discharge flow are calculated during every cycle.

Tank Diameter: Enter the tank diameter in Ft.

Flow Calc. Start Level: See below (in Ft.)

Flow Calc. Stop Level: See below (in Ft.)

Important notes on flow setup:

Set Flow Calc. Start Level at least 4" below the pump start level.

Set Flow Calc. Stop Level at least 4" above the pump stop level.

The flow accuracy is better with longer cycle times (2 minutes or more).

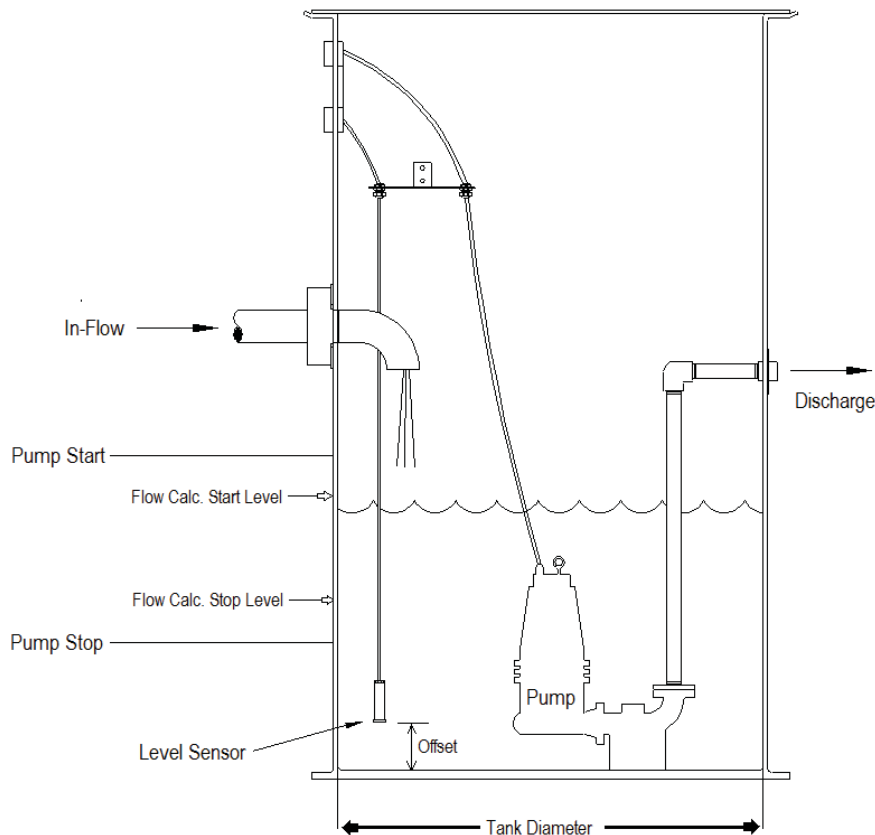

When using a rectangular tank, the equivalent diameter would be: $d=2\sqrt{LxW/\pi}$

Example: A 10X10 tank would equate to a diameter of 11.28. Enter this value and get the flow calculations as if it was a cylindrical tank.
L= length, W= width.

PUMP DATA

The Pump Data screen is for information only. It is a record on the pump HP, Volts, and FLA.

Pump HP: Enter pump horsepower.

Pump Voltage: Enter pump rated voltage.

Pump FLA: Enter pump Full Load Amps (FLA) as shown on the nameplate.

ALARM NOTIFICATION SETUP

You have three options to receive alerts, Email 1, Email 2, and SMS. The user phone number needs to be setup on the users tab (see page 23). Under the **Mobile Phone**, make sure to put a "1" (US/CANADA) before the phone number.

The screenshot shows the 'Users' management interface. At the top, there is a 'Users' header with a user icon. Below it is a toolbar with buttons for 'Edit', 'Save', 'Delete', 'New', and 'Impersonate'. There are two dropdown menus for 'Dealers' (set to 'PRIMEX') and 'Accounts' (set to 'None').

The main content area is split into two panels. On the left is the 'Users List' panel with a search bar containing 'pw' and a list of users: 'amipumpwatch', 'pumpworks', 'pwatch', and 'pweami' (which is highlighted in blue). On the right is the 'User Details' panel for the user 'pweami'. The fields are as follows:

| | |
|-----------------|-------------------|
| User Name | pweami |
| First Name* | PWE |
| Last Name* | AMI |
| Primary Email* | pweami@gmail.com |
| Secondary Email | |
| Mobile Phone | 13335551212 |
| Fax | |
| Comments | |
| Approve Date | 7/7/2015 |
| Language | None |
| Access Level | Account-Admin |
| Accounts | PumpWatch Express |

The 'Mobile Phone' field is highlighted with a red border.

CONNECTING ALERTS TO USER

EMAIL/SMS ALARM NOTIFICATIONS

Click on the alarm indicator to launch the “Bit Alerts” dialog box.

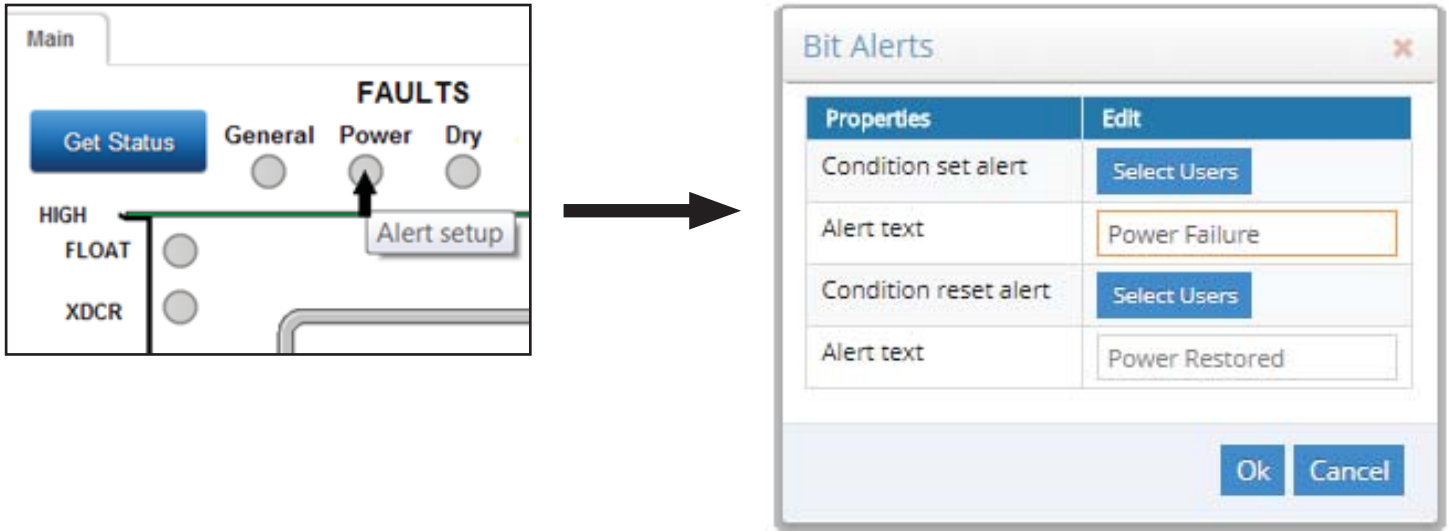

Click on “Select Users” to select which User will be notified when the alarm goes ON (condition set Alert), and when the alarm goes OFF (condition reset alert). Multiple Users may be selected for notification. To create additional Users, see “NEW USER SETUP” on page 19.

Type in the Alert text message that will be delivered. You do not need to include the name of the station in the text as it is always sent as part of the notification.

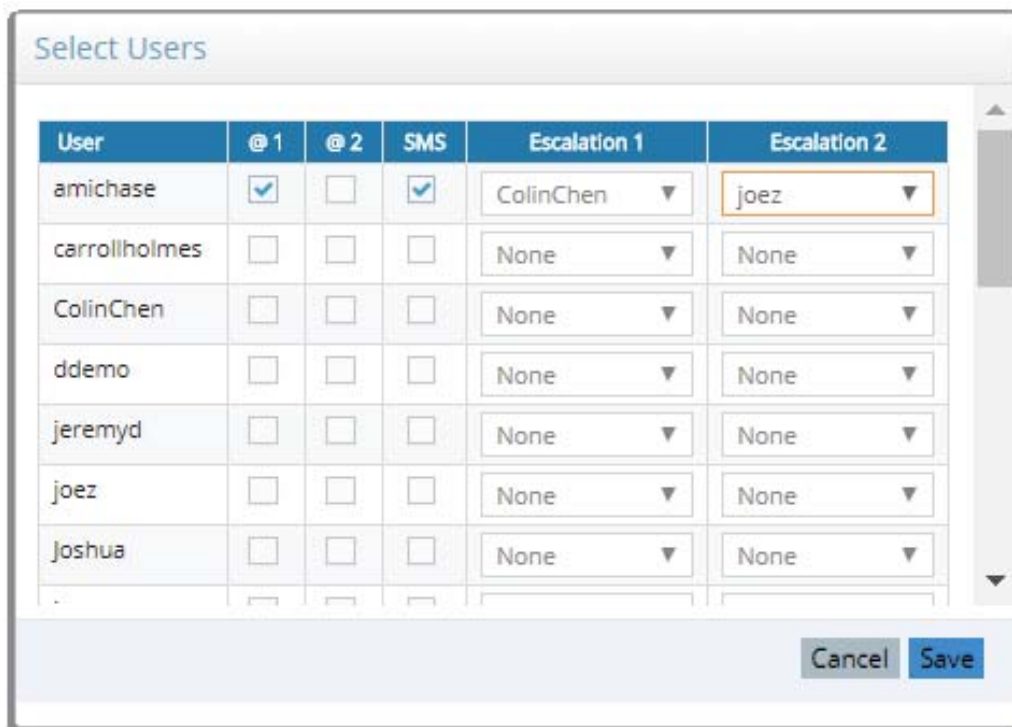

You have three options to receive alerts, Email 1, Email 2, and SMS.

The user phone number needs to be setup on the users tab. under the mobile phone, make sure they have a "1" in front fo their phone number.

In addition to the original SMS message you can assign escalated users. The escalation can happen 2 ways, forced or timed. The forced will be initiated by the users who receive the initial SM by texting a code that will escalate to the assigned user.

Example of SMS sent:

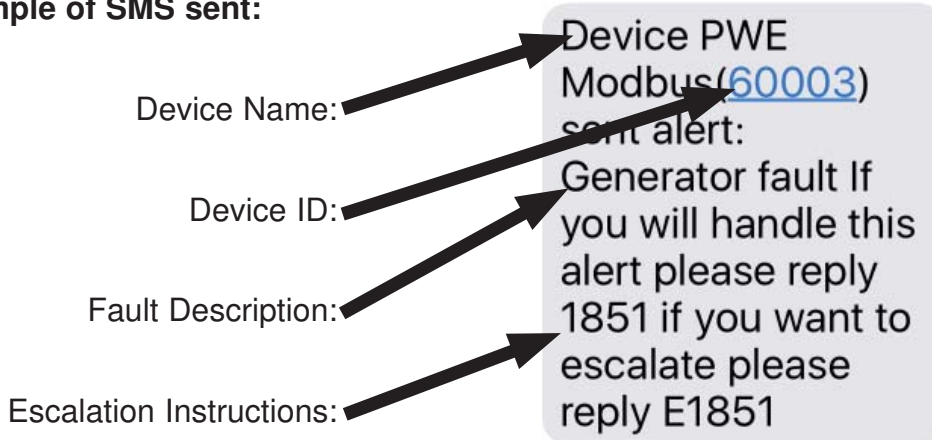

The timed ascaltion will happen when the initial user does not acknowledge the message. The escalation time is fixed at 30 minutes.

EMAIL NOTIFICATION EXAMPLE

Alert Controller # [60003] PWE Modbus

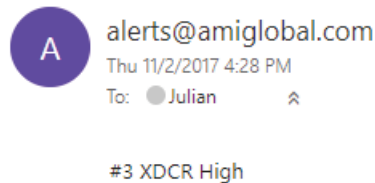

EMAIL TO TEXT

It is possible to convert an email into a SMS (Text). This function is made available by some cellular carriers. Please check with your carrier for more information. Below are some examples:

- AT &T - cellnumber@txt.att.net
- Verizon - cellnumber@vtext.com
- T-Mobile - cellnumber@tmomail.net
- Sprint PCS - cellnumber@messaging.sprintpcs.com
- Virgin Mobile - cellnumber@vmobl.com
- US Cellular - cellnumber@email.uscc.net
- Nextel - cellnumber@messaging.nextel.com
- Boost - cellnumber@myboostmobile.com
- Alltel - cellnumber@message.alltel.com

Example: If your phone number is 111-333-222, and you are with Verizon, the email you should enter to receive a text for notification is 111333222@vtext.com

The SMS report can be found in the Reports tab.

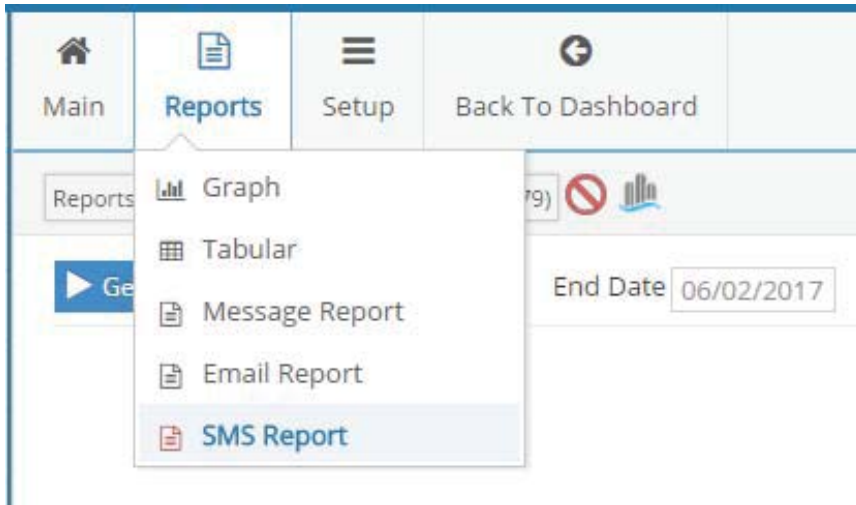

Generate Start Date 10/06/2017 End Date 10/13/2017

| Sent Time | Ack Time | Message | Username | Name |
|---------------------|----------|-----------------|------------|-------------|
| 10/12/2017 02:30 PM | | Generator ok | respjulian | Responsive, |
| 10/12/2017 02:29 PM | | Generator fault | respjulian | Responsive, |
| 10/12/2017 02:26 PM | | Generator ok | respjulian | Responsive, |
| 10/12/2017 01:54 PM | | Generator ok | respjulian | Responsive, |
| 10/12/2017 01:43 PM | | Generator ok | respjulian | Responsive, |
| 10/12/2017 12:40 PM | | Generator fault | respjulian | Responsive, |
| 10/12/2017 12:40 PM | | Generator ok | respjulian | Responsive, |
| 10/11/2017 03:36 PM | | Generator ok | respjulian | Responsive, |
| 10/11/2017 08:33 AM | | Generator ok | respjulian | Responsive, |
| 10/10/2017 10:19 AM | | Generator fault | respjulian | Responsive, |
| 10/10/2017 10:19 AM | | Generator ok | respjulian | Responsive, |

To view Email notifications sent to Users, click on

All notifications sent are logged and can be viewed in a tabular format. The table can be exported to an Excel spreadsheet. (See sample below.)

| Message Time | DeliveredTime | ToAddress | Subject | TextPart |
|----------------|----------------|----------------------|--|-----------------------------|
| 1/10/2014 8:57 | 1/10/2014 8:57 | youremail@server.com | Alert Controller # [7160] LS #10 St Pete Beach | #8 High Level Float - Reset |
| 1/10/2014 8:52 | 1/10/2014 8:50 | youremail@server.com | Alert Controller # [7160] LS #10 St Pete Beach | #4 Power Fail - Rest |
| 1/10/2014 8:50 | 1/10/2014 8:50 | youremail@server.com | Alert Controller # [7160] LS #10 St Pete Beach | #8 High Level Float |
| 1/10/2014 8:36 | 1/10/2014 8:26 | youremail@server.com | Alert Controller # [7160] LS #10 St Pete Beach | #1 Fault Acknowledged |
| 1/10/2014 8:29 | 1/10/2014 8:29 | youremail@server.com | Alert Controller # [7160] LS #10 St Pete Beach | #3 Power Fail |

REPORTS & TRENDING

5 types of reports are available:

-Graph gives you the ability to view historical trends of various data point.

-Tabular allows you to view and export data in a .csv file or Excel file.

-Message reports are notifications generated from the server.

-Email list all notifications sent in a valid email address.

-SMS lists all notifications sent via SMS to a smart device.

Reports are very useful for evaluating the health of the pumping station and for detecting abnormal operation. Example: High inflow from water infiltration from a storm or other event. This data can be downloaded in various format and shared. Click on the “Report” icon on top of the screen and select the type of report to view. Example. Click on Graph then select In-Flow GPM to view chart..

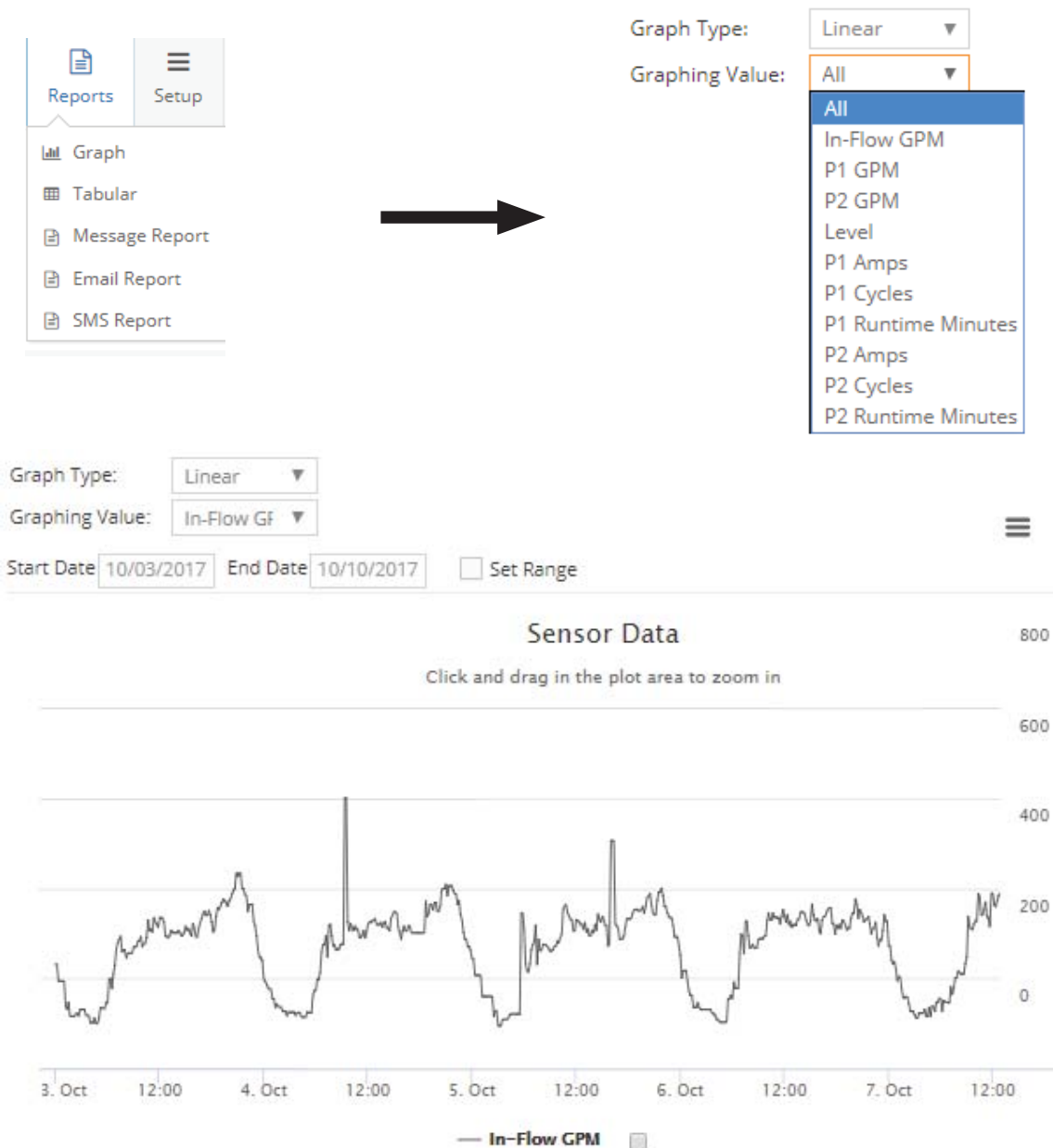

Click on Start Date and End Date to select data time range. Large ranges will take longer to download.



Click on **Generate** to create the graph.

You can zoom by clicking and dragging your mouse on a particular area on the graph. Click on "Reset zoom" to go back to the previous view.

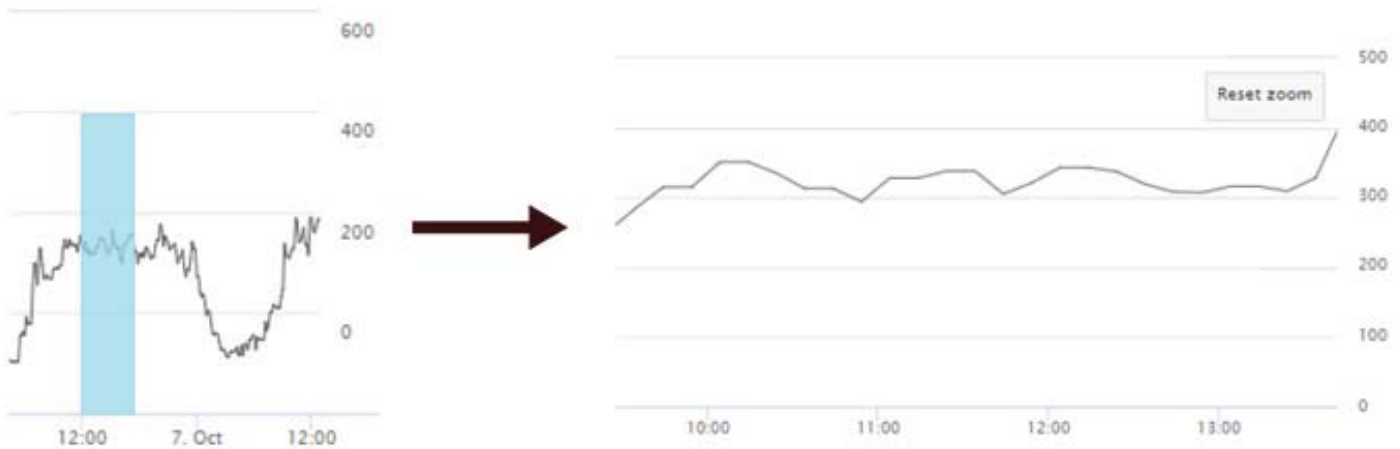

You can view all graphs at the same time. Click on the data labels below the graph to turn OFF the pens you do not wish to display. This enables you to compare data. Example P1 and P2 Amps.

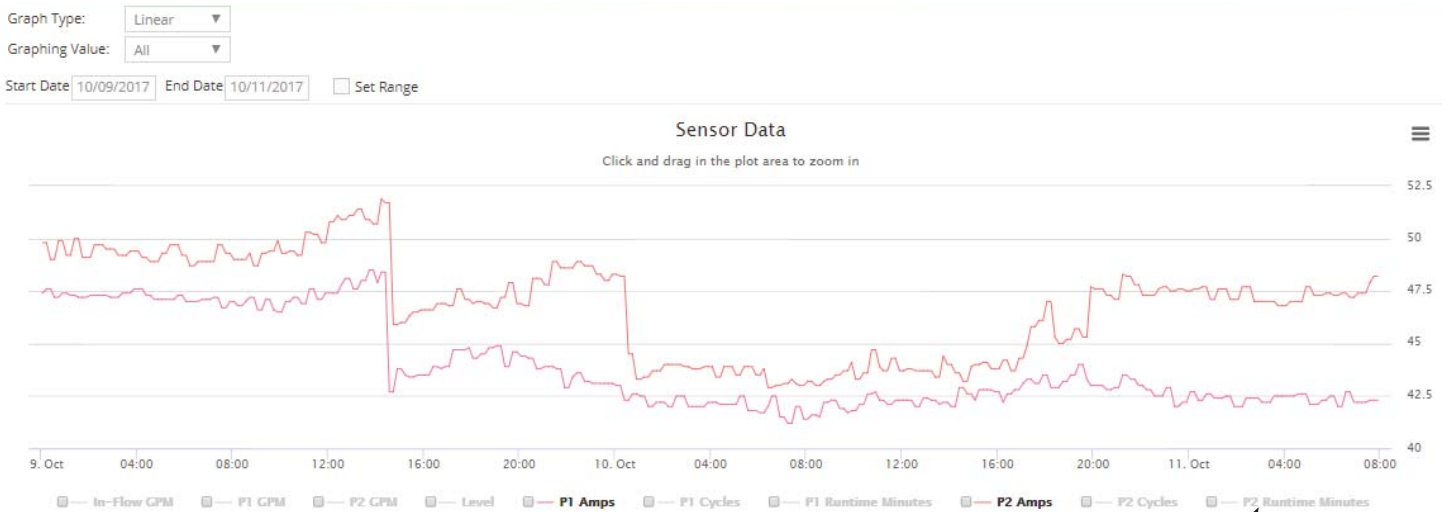

Click on  to view export options.

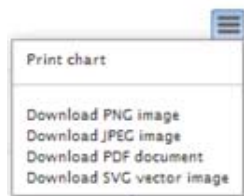

Click on label  to turn OFF pen.

To view accumulation data, select “Accumulation”. This function is used to view Run times & Cycles on select versions.

Graph Type: Linear ▼
Graphing Value: Linear
Average
Accumulation

▶ Generate

Graph Type: Accumula: ▼
Time Period: Daily ▼
Graphing Value: All ▼

Start Date End Date Set Range

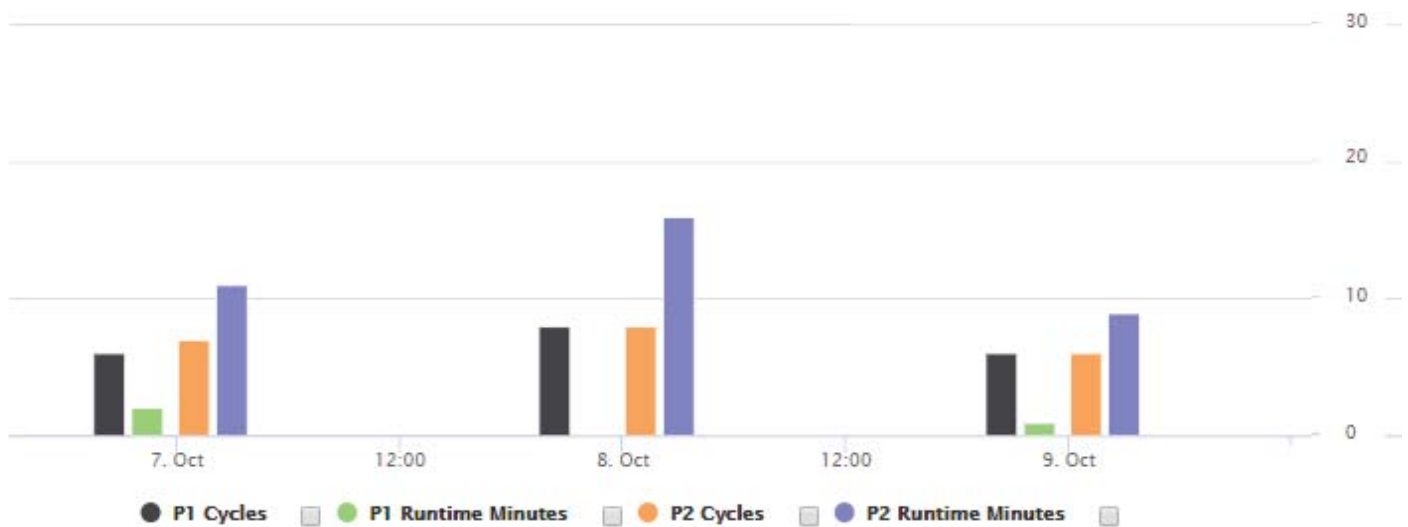

When you are finished with your session, please logout of the system.

Welcome, 78

- Download
- Dealers
- Accounts
- Users
- Manage Inventory
- Register Device

Logout

CUSTOMER SERVICE AGREEMENT AND TERMS OF USE

After you verify and activate your account and login for the first time you will need to agree to the Terms of Use. This step only needs to be completed during the initial setup and activation of your account. You can review this document at any time thereafter on the web portal after successful login.

This document (outlined below) is the agreement between AMI and the end User and must be agreed to before access to the cloud interface is allowed.

Only the end User should activate this product. When the initial 1 year of cellular service comes to an end, AMI will contact you directly and review renewal options. The primary User (Account Admin) is able to add additional Users for login and alarm notification. The cellular service plan provided only covers text (SMS), and data for the Pump Watch Express™ unit. It does not cover SMS and Data service charges incurred for the use of your personal cell phone or tablet.

Pressing the Ok button you declare that you have read and agree to these Terms of Use

This agreement (hereinafter referred to as the "Agreement") is entered between Aqua Management, Inc. a Nevada Company, (hereinafter referred to as "AMI") and the entity or individuals utilizing AMI's products and services, including its web site and database information (hereinafter collectively referred to as the "Customer") and is effective upon activation and use by Customer of AMI's products and services.

The Parties:

AMI is engaged in the business of providing wireless communications and database systems for managing and monitoring remote equipment in a supervisory manner, including such industrial applications as agriculture, oil, gas water and wastewater systems. The Customer desires to use and benefit from AMI's communications and database system, which is to be installed by the Customer on-site at the Customer's premises.

Customer acknowledges and understands that by activating and utilizing AMI's products, services, web site and/or data-based information, Customer is agreeing to be bound by the following terms contained in this legal agreement.

The Terms

In consideration of the above recitals, the mutual promises contained herein, and other good and valuable consideration, including Customers use of AMI's products and services, the parties hereby agree as follows:

1. Customer agrees to pay AMI for hardware and monthly monitoring fees as defined in AMI invoices, and AMI agrees to provide Customer with monitoring and notification services by utilizing automated texting, e-mailing and/or TCP/IP transfer of data to Customer's designated destinations as set forth in the AMI web site database on a best efforts basis. For additional operational and functional details, Customer should refer to the AMI product instructions.
2. Customer understands that AMI will not, with its own personnel, respond to or take action related to those events about which AMI provides monitoring and notification. Customer further understands that he/she is solely responsible for the final entries and schedules set forth in the AMI database, notwithstanding the fact that AMI may have entered the monitoring and notification information in that database on the Customers behalf.
3. Customer also understands that the data entries and schedules, residing in AMI's database, can be changed by the Customer. Customer further understands and agrees to bear the risk of loss or damage that may result from changes to the AMI database made by, or on behalf of the Customer, and that such changes may impair or prevent the AMI notification system from providing timely and successful notifications of detected events to Customer's designated destinations.
4. Customer further understands that AMI makes no representations, promises, warranties, or guarantees that there will be no interruptions in service, delays in performing service, or as to the quality, usefulness, completeness and reliability of such service. Furthermore, that AMI provides no assurances that such service will be free of errors. Customer acknowledges that AMI utilizes wireless data services that may be provided by cellular and various participating carriers, and that such providers disclaim any and all liability arising from the Customer's use of AMI's products and services. Customer further understands that AMI has no control of, or responsibility for, the texting, cellular, radio, telephone, Internet, or other communication medium which the customer may rely upon for delivery of alarm or other messages sent by AMI.
5. Customer also understands that in further consideration of being granted the right to utilize AMI's monitoring and notification service, the Customer, on behalf of himself/herself, and any employees, agents, personal representatives, assigns, heirs, next of kin and any third party, agrees:

- A. To indemnify, defend and hold harmless AMI, its owners, directors, officers, employees, agents, suppliers or affiliated companies, against any and all claims, demands or actions based upon any losses, liabilities, damages or costs, whether direct or indirect, special or consequential, including attorney's fees, that may result from the operation of AMI's products and services, or from the failure of the AMI system to report a given event or condition
- B. To release, waive, discharge and covenant not to sue AMI, its owners, directors, officers, employees, agents, suppliers or affiliated companies, for any and all liabilities potentially arising from any claim, demand or action based upon any losses, liabilities, damages or costs, whether direct or indirect, special or consequential, including attorney's fees, that may result from operation of AMI's products and services, or from the failure of the AMI system to report a given event or condition.
- C. That in the event AMI is found to be liable for any loss or damage arising out of mistakes, AMI's, interruptions, delays, errors or defects in AMI's products or services, such liability shall not exceed the total amount paid by the Customer to AMI for the services or \$250.00, whichever is greater.
- D. That the AMI hardware includes a limited warranty that the product is free from defects in materials and workmanship for a period of one year from the date of delivery. AMI's obligation under this limited warranty is limited to repairing or replacing the product, at AMI's option, unless the product has been misused or improperly repaired or serviced by any party other than authorized AMI personnel, in which case the limited warranty is voided. Other than this limited warranty, AMI's products and services are provided with no other guarantees or warranties, express or implied, including any warranties of merchantability or fitness for a particular purpose.
- E. That neither AMI nor its owners, directors, officers, employees, or agents are an insurer and that the Customer is to maintain their own insurance coverage sufficient to provide compensation for any loss, damage, or expense that may arise in connection with the use of AMI's products or services.
6. Customer further understands and agrees that AMI's products and services are intend to monitor and notify Customer of events only relating to Customers non-critical mechanical and electrical equipment and are not intend to be use for a primary life-safety, burglary, fire-detection and reporting system.
7. Customer is responsible for the ongoing, periodic testing of the AMI system, and shall notify AMI immediately if any failures are found. AMI shall use all reasonable efforts to identify and resolve the perceived failures, but in no case will be obligated to travel to the Customer's premises to perform diagnostic or corrective actions.
8. Should the Customer choose to utilize AMI equipment and services to perform manual or automatic control for external equipment such as pumps, wells, or valves, Customer acknowledges that AMI performs this service on a best efforts basis. AMI recommends that Customer not rely on AMI solely for the control of remote relay activated devices and that customer should make provisions for alternate means of remotely or locally operating said controls. AMI strongly recommends that Customer make electrical or mechanical provisions at the remotely controlled site equipment that will alleviate, or reduce the risks associated with the failure by AMI to properly control said remote relay control functions. Customer understands and acknowledges that there are other providers of such remote or local control technologies.
9. Customer agrees to pay AMI for a monthly per unit monitoring fee, which is to be prepaid on an annual basis, as indicated in Customer's invoice. The first annual service fee and hardware cost are to be paid within 30 days from the date of shipment of the AMI hardware. Although the hardware cost and monitoring fees are due and payable within 30 days of shipment from AMI's factory, Customer may receive up to 90 days of service credit on the first term service, per monitored unit, for units not installed up to 90 days after shipment. Units not installed within 90 days from shipment will be billed as active, whether installed or not. Service credit will be applied to the second-year service period. After the expiration of the initial one-year term, this Agreement shall automatically renew for additional one-year periods, unless canceled by written notice to AMI at least sixty (60) days prior to expiration date of the then current term. Once a field RTU is in service, AMI shall not increase that device's annual monitoring fees by an amount greater than the percentage increase in the United States Bureau of Labor Statistics "Consumer Price Index."
10. The Customer understands the intended uses of AMI's products and services and will ensure that they are used in an intended and safe manner. AMI reserves the right to remotely take out of service any field unit that generates more than twenty five (25) alarm messages in any one day period. AMI may keep the offending field unit out of service until AMI and the Customer have agreed how to prevent the unit from transmitting further excess messages or made alternative arrangements. In addition, it is agreed that AMI personnel will be contacted if the Customer does not know how to install or operate AMI's products and services.
11. The Customer acknowledges that he/she has read and understands this Customer Service Agreement, and that he/she agrees to its terms and intends to be bound by them. The Customer further understands that this Agreement is intended to be as broad and inclusive as is permitted by law and that if any portion thereof is held invalid. It is agreed that the balance of the agreement shall, notwithstanding, continue in full legal force and effect.
12. Regardless of the place of contracting or performance, this Agreement and all questions relating to its validity, interpretation, performance and enforcement shall be governed by and construed in accordance with the laws of the State of Nevada, and that any suit, action or other legal proceeding involving this Agreement shall be brought exclusively within the State or Federal Courts of Las Vegas, Nevada.
13. The parties hereto acknowledge and agree that this Agreement contains the entire agreement between AMI and the Customer, and that there are no other representations, inducements, promises, or agreements, oral or otherwise, which are not embodied herein.



844-4PRIMEX (477-4639)

WWW.PRIMEXCONTROLS.COM