

PC-2000

DUPLEX PUMP CONTROLLER

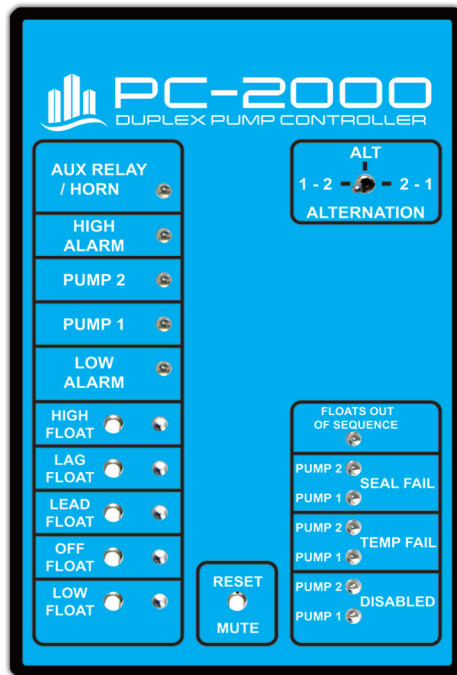

User Manual



1.0 INTRODUCTION

The model PC-2000 is a float switch based dual pump controller intended primarily for wastewater lift stations and other pump down applications. It has inputs for five normally open float switches and sensor inputs for the seal fail and temperature fail sensors normally found in submersible pumps. The controller has indicator lamps and test push button switches on each of the float inputs as well as an indicator which illuminates if the floats do not close in the correct order. The controller has built in alternation and a three position switch to select automatic alternation or to select between pump 1 and pump 2 if alternation is off. The controller has disable inputs for each of the pumps. The controller has built in support for an alarm horn with inputs for an external mute button and also a mute button on the controller front panel. There are two alarm outputs. One for the high alarm and one for the low alarm. These output relays can be setup to cycle on and off during an alarm to support a blinking panel alarm light. The controller has five output relays. Two are for the two pumps, one each for the high and low level alarms, and one to drive the horn. The controller has indicator lights and external relay drivers for the following conditions (floats out of sequence, seal fail for pumps 1 and 2, temperature fail for pumps 1 and 2, pump disabled for pumps 1 and 2).

2.0 OPERATION

The PC-2000 uses five normally open float switches for level sensing. When the tank is empty all of the floats are open. The lowest float is the low alarm float. If it is not used the low float input should be shorted with a jumper. When the tank is empty the controller will be in the low alarm condition. On rising water when the level is high enough to close the low float switch then the low alarm will turn off. As the level rises the off float will close and then the lead float will close. When this happens the pump controller will call for the lead pump. Which pump is the lead, will be determined by the alternator. If the alternator is set for pump 1 then pump 1 will be called. If the alternator is set for pump 2 then it will be called. If the alternator is set in the on position then each pump cycle the lead pump will change. If one of the pumps has an existing leak failure then the other pump will be called as the lead. If any pump has existing temperature failure or is disabled then that pump will not be called. If the lead pump lowers the water level far enough to open both the lead and off floats then the lead pump will be turned off and the lead pump changed if alternation is on. If the water level continues to rise and closes the lag float then the lag pump will be called. If the level drops enough to open the lag, lead, and off floats then the two pumps will be turned off. When both pumps are turned off there is a 4 second delay between the first and second pump turning off. If the water level continues to rise and closes the high alarm float then the high alarm condition will be set. This will cause the high alarm relay and light to come on. This alarm condition will clear when the level is low enough to open the high float. Any time a pump is started an internal timer is started which will prevent the other pump from starting for a period of time which is selected by one of the option switches on the bottom of the controller. This time can be either 6 or 12 seconds.

The controller has three pairs of inputs for setting pump related alarms or faults.

SEAL FAIL INPUTS

Each pump has an input for the seal fail (moisture) sensor commonly found in submersible pumps. The controller measures the resistance of the sensor. In normal operation the seal fail condition is set if the resistance is less than 50,000 ohms. One of the option switches can be used to change this to set the alarm if the resistance is greater than 50,000 ohms. If a seal fail alarm is set then that pump is demoted to lag pump and its seal fail lamp and output are activated. The seal fail does not disable the pump.

TEMPERATURE FAIL INPUTS

Each pump has an input for the temperature fail sensor often found in pumps. This sensor should be shorted if the pump is good. If the pump overheats then this sensor will open. The sensor is connected to ground and to the sensor input for that pump. If the pump controller detects an open condition in the sensor then the temperature fail lamp and output are activated. The temperature fail condition will disable the pump. The controller can be set using an option switch on the bottom of the controller to latch up the temperature fail condition. If this option is selected then once a temperature fail condition is detected the fault will not clear until the fault condition is cleared and the reset push button is pushed (or external reset input is closed). If this option is not selected then the fault will clear when the sensor in the pump closes again.

DISABLE / PUMP RUNNING INPUTS

Each pump has an input which has two possible functions. If the fail to start test is not activated by an option switch on the bottom of the controller these inputs are pump disables. Under this condition, if this input is shorted to ground then that pump will be disabled. If the fail to start test is activated these inputs are pump running inputs and should be shorted to ground when ever the pump is running.

FAIL TO START TEST

If the fail to start test is activated (using the option switches on the bottom of the controller) then the following sequence is used each time a pump is called:

1. When a pump is called a timer is started.
2. After a start up time has expired (set by switch 6) the pump running input is checked. If the pump is not running at the end of the time then a pump fail to start condition is set and the pump is disabled. The pump will remain disabled until the reset button is pushed, a high level alarm is set, or until the external reset input is activated.

ALARM RELAY OUTPUTS

The controller has two relays for level alarm. Option switch 5 can be used to cause these relays to cycle on and off. This is useful to provide blinking on the external alarm lights.

AUXILIARY RELAY

There is one relay which can have either of two functions selected by option switch 4.

1. If the horn option is selected then this relay can be used to drive an external horn or bell. Whenever either a high or low alarm condition starts the relay is activated (closed). If the alarm condition is cleared then the relay is also cleared. If the reset button is pushed or the external reset/mute input is activated then the horn relay is cleared. If the horn is muted then it will not reactivate until the alarm condition is cleared and another starts.

2. If the common alarm option is selected then this relay will be activated when any of the following conditions exist:

- High alarm
- Low alarm
- Pump Temperature Failure
- Pump disabled by fail to start test

This common alarm condition can be used to drive an alarm light, telephone dialer, or telemetry system.

OPTION SWITCHES

There are six switches on the back of the controller which select several different options.

SW1 / When this switch is set the fail to start test is enabled

SW2 / When this switch is set the temperature fail condition is latched up until reset

SW3 / When this switch is set the seal fail input is inverted (open is fault)

SW4 / When this switch is set the aux relay is the common alarm. If it is not set then the aux relay is the horn output.

SW5 / When this switch is set the low and high alarm relays will cycle to cause a lamp blink

SW6 / When this switch is set the time between pump starts and the delay for the fail to start test is 12 seconds instead of 6 seconds

FAULT OUTPUTS

There are seven fault lamps with corresponding driver outputs. They are use to display the following fault conditions:

1. Floats out of sequence
2. Pump 1 seal fail
3. Pump 2 seal fail
4. Pump 1 temperature fail
5. Pump 2 temperature fail
6. Pump 1 disabled
7. Pump 2 disabled

Each of these has a corresponding relay drive output. These outputs are designed to drive the coil of a 12VDC relay external to the controller. A source of 12VDC is also provided. To use these outputs one side of the relay coil is connected to 12VDC and the other coil connection is connected to the driver output.

3.0 SPECIFICATIONS

3.1 Float and Sensor Input

There are five float inputs, two seal fail sensor inputs, two temperature fail inputs, and two disable inputs. They use current limiting resistors, filter capacitors and zener diodes for transient protection. They also have both a hardware and a software filter on these inputs to improve immunity from noise. They have the following specifications:

- Short Circuit Current - less than 2 mA.
- Open Circuit Voltage - 5.0 VDC

3.2 Mute / Reset Input

The mute / reset input is intended for use with a momentary push button switch mounted on the dead front or on the side of the enclosure. It has the following specifications:

- Short Circuit Current - less than 2 mA.
- Open Circuit Voltage - 5.0 VDC

3.3 Relay Outputs

There are five relays which are used for pumps and alarms. All of them except the low alarm relay are form A (SPST) relays. The low alarm is a form C (SPDT) relay. They have the following specifications:

- Maximum current at 120 VAC 7 Amps with a resistive load
- Maximum voltage - 140 VAC

3.4 Power Inputs

The controller is designed to run on 120 VAC control power. It is internally fused at 1 Amp and transient protected with a MOV transient protector. It uses transformer isolation and internal current limited voltage regulators. It has the following specifications:

- Input Voltage 120 VAC + or – 10% 50 to 70 Hz.
- Maximum Current 0.4 amps

3.5 Operating and Storage Temperature Range

- Operating Temperature - 10 degrees C to 60 degrees C
0% to 95% relative humidity, non-condensing
- Storage Temperature - 20 degrees C to 65 degrees C
0% to 95% relative humidity, non-condensing

3.6 Fault Driver Outputs

The controller has seven open drain FET driver outputs for driving external relays, lights, telephone dialers, or remote terminal units. The outputs short to ground when activated and have the following specifications:

- Maximum voltage +12VDC
- Minimum voltage 0.0 VDC
- Maximum continuous sink current +0.4 Amps
- Maximum on resistance 2 ohms

Notes: Header and plugs use copper conductors only.
Torque requirement for plugs 1.47 Ft. Lbs.
Unit operates at "Pollution Degree 2".

4.0 CONNECTOR PIN DEFINITIONS

CONNECTOR J1

PIN FUNCTION

1	120 VAC HOT POWER INPUT TO THE CONTROLLER
2	120 VAC NEUTRAL POWER INPUT TO THE CONTROLLER
3	GROUND
4	GROUND
5	AUX RELAY CONTACT
6	AUX RELAY CONTACT
7	HIGH ALARM RELAY CONTACT
8	HIGH ALARM RELAY CONTACT
9	PUMP 2 RELAY CONTACT
10	PUMP 2 RELAY CONTACT
11	PUMP 1 RELAY CONTACT
12	PUMP 1 RELAY CONTACT
13	GROUND
14	LOW ALARM RELAY NORMALLY OPEN CONTACT
15	LOW ALARM RELAY COMMON CONTACT
16	LOW ALARM RELAY NORMALLY CLOSED CONTACT

CONNECTOR J2

PIN FUNCTION

1	PUMP 1 TEMPERATURE SENSOR INPUT
2	HIGH FLOAT INPUT
3	LAG FLOAT INPUT
4	LEAD FLOAT INPUT
5	OFF FLOAT INPUT
6	LOW FLOAT INPUT
7	PUMP 1 DISABLE / RUNNING INPUT
8	PUMP 2 DISABLE / RUNNING INPUT
9	PUMP 1 SEAL FAIL SENSOR INPUT
10	PUMP 2 SEAL FAIL SENSOR INPUT
11	PUMP 2 TEMPERATURE SENSOR INPUT
12	MUTE / RESET INPUT

CONNECTOR J3

PIN FUNCTION

1	+12 VDC VOLTAGE FOR EXTERNAL RELAYS
2	PUMP 1 DISABLE OUTPUT
3	PUMP 2 DISABLE OUTPUT
4	PUMP 1 TEMPERATURE FAIL OUTPUT
5	PUMP 2 TEMPERATURE FAIL OUTPUT
6	PUMP 1 SEAL FAIL OUTPUT
7	GROUND
8	PUMP 2 SEAL FAIL OUTPUT
9	FLOATS OUT OF SEQUENCE OUTPUT
10	RS232 RECEIVE
11	RS232 TRANSMIT
12	AUXILIARY INPUT

PC-2000
 DUPLEX PUMP CONTROLLER

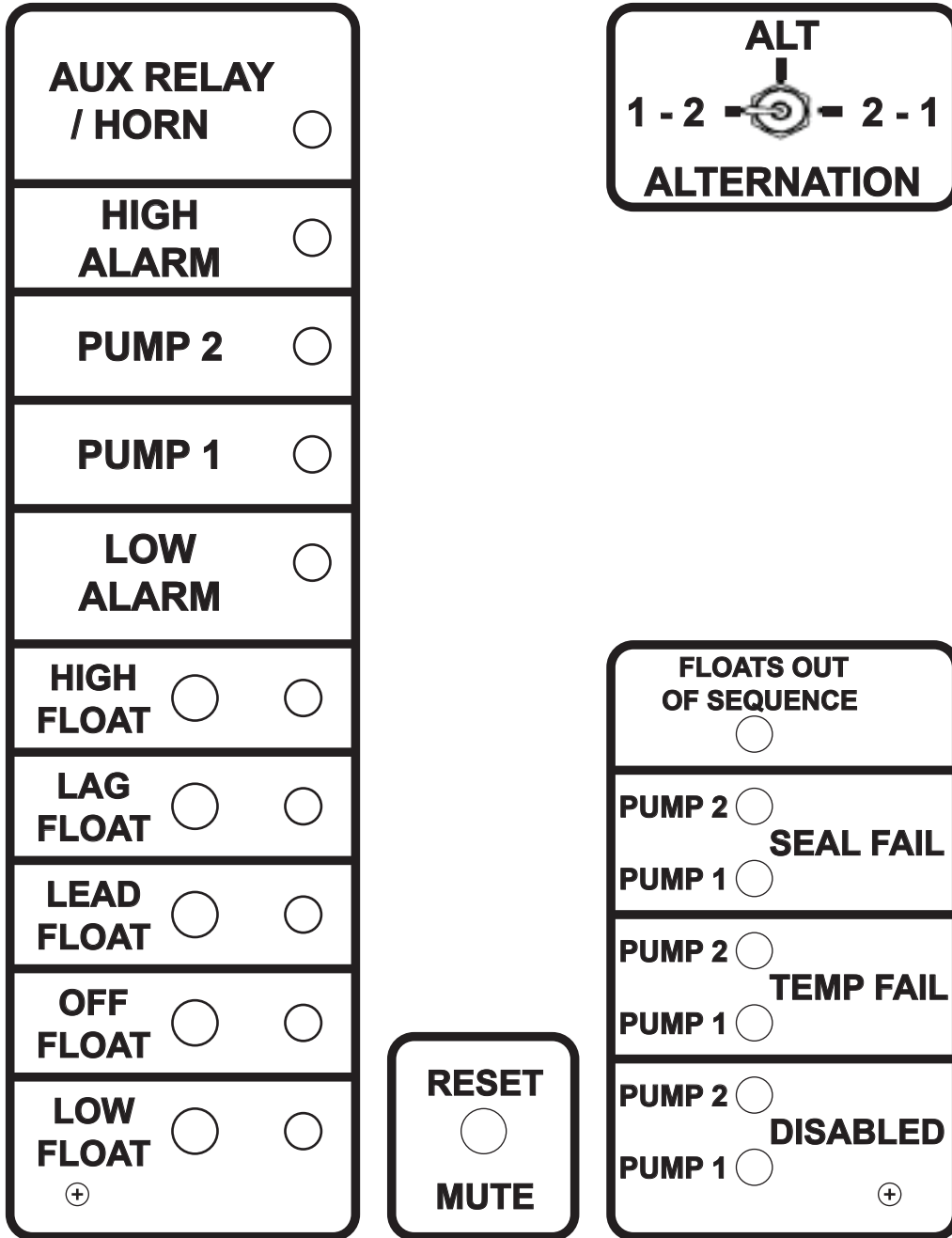
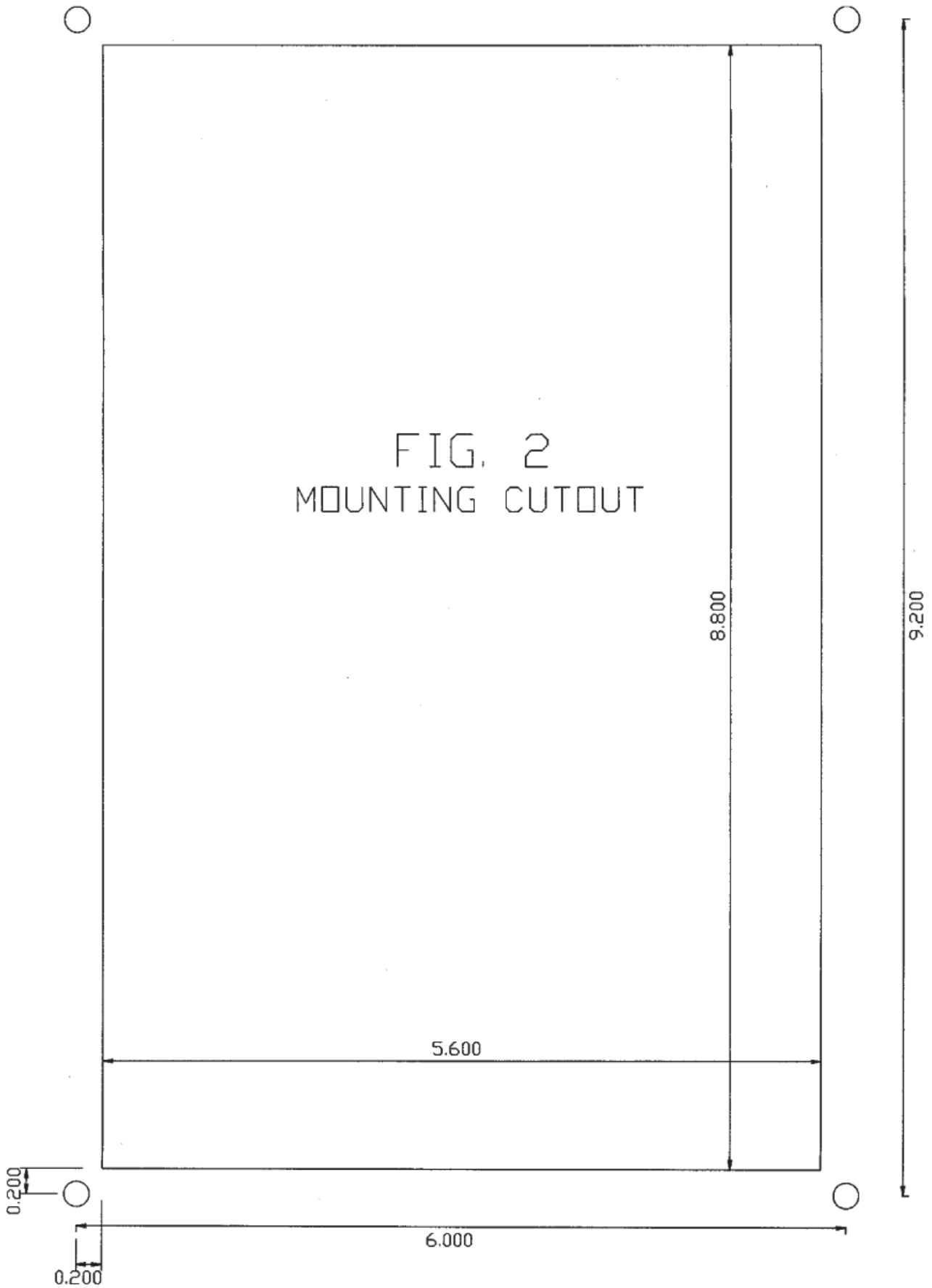

FIG. 1 FRONT PANEL

FIG. 2
MOUNTING CUTOUT



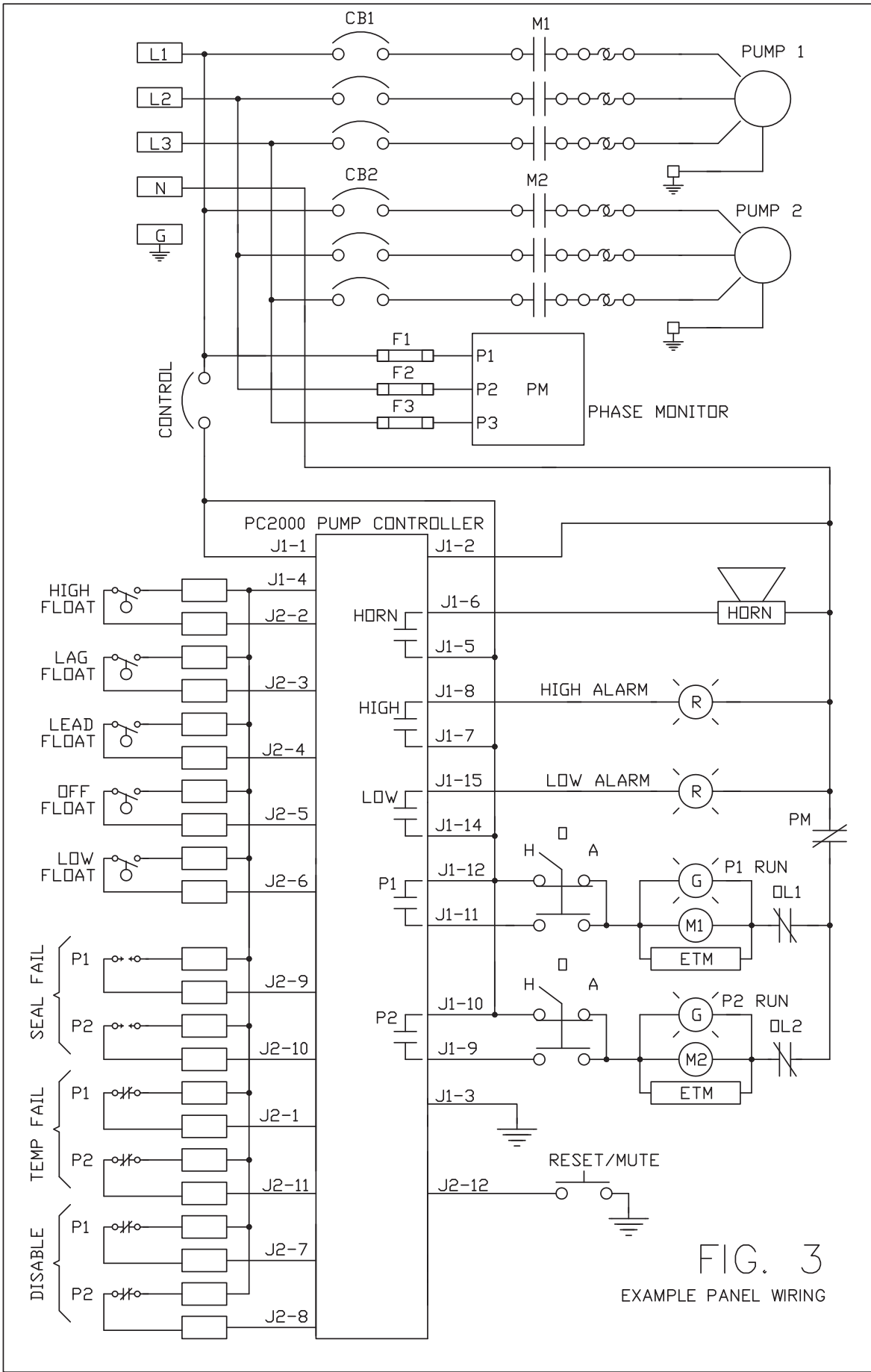

FIG. 3
EXAMPLE PANEL WIRING

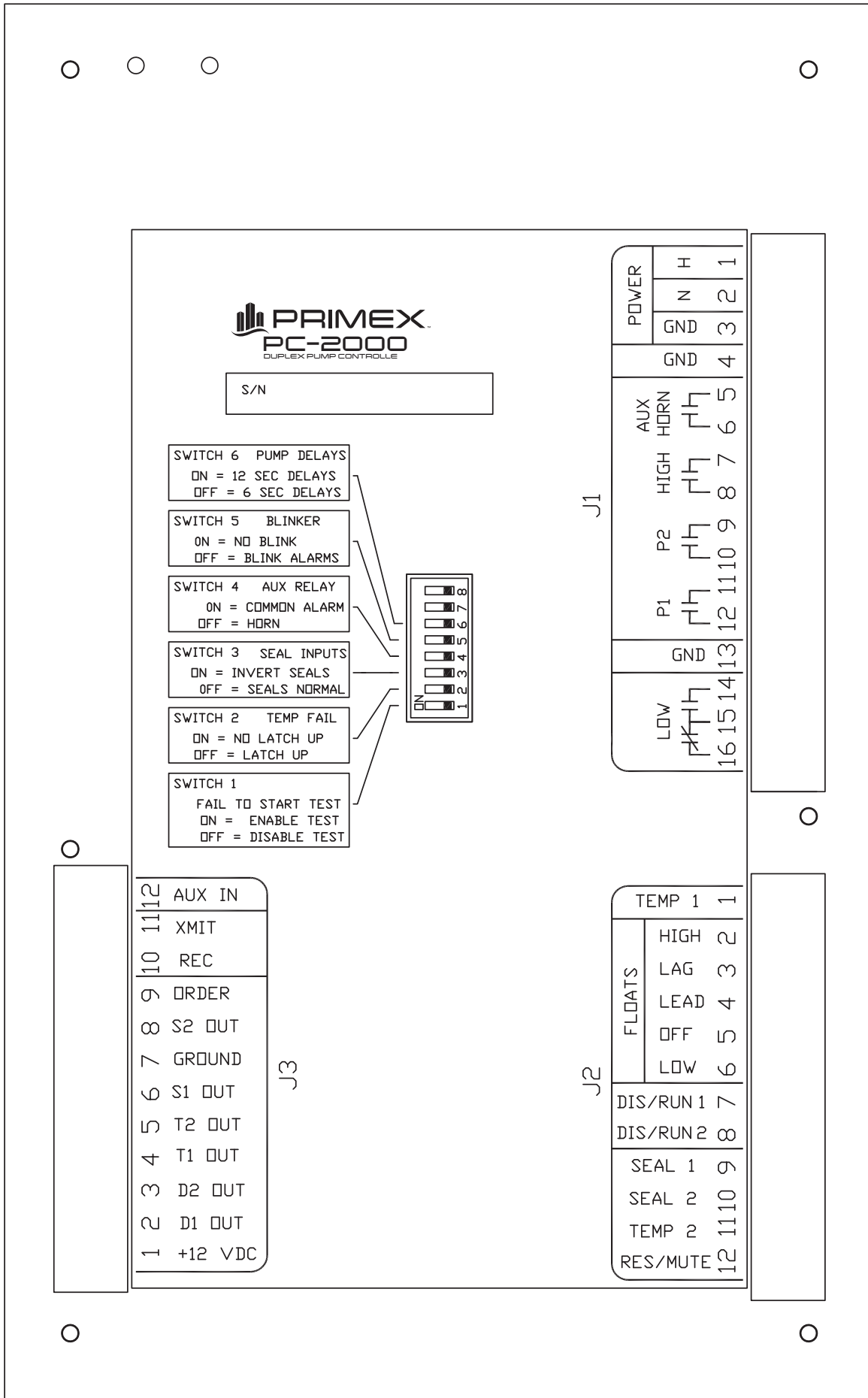

FIG 4 PC-2000 BACK VIEW



+1-844-4PRIMEX (477-4639)
WWW.PRIMEXCONTROLS.COM